

Response to the Referee #1

First, we thank all reviewers for their time and critical review of the manuscript. As such, the manuscript is much more focused and streamlined. Our point-to-point responses to the reviewer are given below. For clarity, all responses are provided in blue.

Referee: 1

Recommendation: This paper presents a careful analysis of the optical properties of biomass-burning aerosol particles and selected trace gases in northern Thailand based on ground-based observations. It nicely characterizes the aerosol optical thickness, absorption properties, and size characteristics, and where relevant, compares to comparable measurements by the well-characterized AERONET sun/sky radiometer. The text is quite clear and much improvement in the presentation would be accomplished by attention to improving the figures, scales, and labels. I recommend this paper be accepted for publication with only minor editorial changes, especially with regard to figure quality suitable for publication.

Ans) We sincerely appreciate your kind comments and suggestions. Please find our line-by-line responses below.

General Comments:

1. This important paper is generally well written and easy to follow, but confusion easily arises when referring to the figures (and tables), that could be improved for publication.

Major Comments:

1. The labels on the axes of the many Figures use too small a font size, and they are not easily readable (e.g., Figure 11, 12, 14). Attention should be given to readability. Since many of the figures may be published on a single column rather than across two columns, attention should be given to all font sizes:

- ➔ Figures 11 and 12 – The labels on the axes are too small, and the legends in each panel that show statistics are even smaller. It is not obvious how to make them more readable as there is a lot of information in the legends, but it makes the figures hard to decipher without enlarging the figure on a computer.

Ans) As the referee suggested, we updated the figures in the revised manuscript.

- ➔ Figure 14 – The labels in the legend on Figure 14b are too small to decipher, as they show the results for 3 wavelengths.

Ans) As the referee suggested, we updated the figure in the revised manuscript.

- ➔ Figures A1 and A2 – the legends and axes labels are also too small to read easily.

Ans) As the referee suggested, we updated the figures in the revised manuscript.

Minor Comments:

1. Page 2, line 51 – change ‘its absorption’ to ‘their absorption.’

Ans) Thanks for the correction. We revised the sentence as suggested.

2. Page 7, line 199 – change ‘SMART-s is’ to ‘SMART-s are.’

Ans) Thanks for the correction. We revised the sentence as suggested.

3. Page 18, line 568 – ALH is not defined at this, its first us. Please define Aerosol Layer Height (ALH) when first used.

Ans) Thanks for the correction. We revised the sentence as suggested.

4. Page 18, line 589 – reference to the solar zenith angle being ‘low’ should probably change to ‘small’ to make sure it is clear that it is high sun and small solar zenith angle (if I understand it correctly).

Ans) Thanks for the correction. We revised the sentence as suggested.

5. Page 24, line 758 – Change ‘Jhon Cooper’ to ‘John Cooper.’

Ans) Thanks for the correction. We revised the name as suggested.

Response to the Referee #2

First, we thank all reviewers for their time and critical review of the manuscript. As such, the manuscript is much more focused and streamlined. Our point-to-point responses to the reviewer are given below. For clarity, all responses are provided in blue.

First review of “Simultaneous retrievals of biomass-burning aerosols and trace gases from the ultraviolet to near-infrared over northern Thailand during the 2019 pre-monsoon season” by Jeong et al. (April 11, 2022)

Reviewer Recommendation: Requires major revisions before publication

Summary:

The submitted manuscript discusses measurements from the SMART-s instrument. The SMART-s instrument is a ground-based spectrometer mated to a scanning head with imbedded filter wheels used to measure direct sun and diffuse sky radiances. The instrument is described in fairly sparse detail, but the calibration procedure and data preparation are described in much more detail. From the spectra measured, retrievals of aerosol optical properties are performed. Those retrieved values are compared to ancillary instrumentation including an AERONET instrument. In general, the data presented seem reasonable and show good correlation with previously described instrumentation. This is perhaps not surprising as the instruments chosen for comparison are all passive remote sensing instruments with spectrally resolved data streams. In general, the results seem reasonable and the methodology sound, but the presentation of those results is quite confusing in my opinion. The citations are simultaneously very clear and maddeningly unhelpful. The major issues of the manuscript, in my opinion, relate to the way the data are organized, presented, and described. In general, the clarity of data presentation is, in my opinion, poor and is an area of substantial concern. My comments below outline the issues I see in more detail.

I would suggest that the information contained within the article is novel and publishable, if not somewhat incremental, but that major revisions are required to the manuscript to make the data presentation clear and precise.

Major Comments:

1. The scope of this paper seems to be somewhat confusing in my opinion. Specifically, I have 2 major comments:
 - a. It seems that the novel element of this manuscript is combined aerosol and gas retrievals and the hardware that facilitates that. However, the text focuses at times on other elements that seem to be reported elsewhere.
 - i. Trace gases are frequently mentioned, but never really addressed in any great detail. It seems, based on lines 228-230 that this is intended to be a second manuscript or companion paper. To me, it seems that a large part of the novelty of this work is the combined retrieval of aerosol properties and trace gases, leaving a feeling that the presentation of information is incomplete.

Simply stated, I don't believe that the trace gas retrievals can be omitted and be called self-contained.

→ As the referee suggested, we inserted Appendix B (SMART-s ozone and water vapor retrieval algorithm) in the revised manuscript.

- ii. Lines 199-217: The scanning head, which is stated as being reused from the Pandora network, is described in more detail than the spectrometer, which is novel.

→ We understand the referee's concern, but we believe that this demonstration is helpful for some readers who are not familiar with the Pandora instruments. In addition, the FOV of different filter-wheel combinations described in this section may vary depending on the units, therefore, it needs to be specified.

- iii. Section 2.3: The radiometric calibration procedure of the hardware is exceptionally well described. That said, it appears to me to not be novel. If that is true, the section could be substantially shortened or moved to an Appendix to focus on the truly novel.

→ As the referee commented, the coauthors have discussed intensively whether this part should be in the main manuscript or in the Appendix. But we all agreed to keep Section 2.3 in the main manuscript for the following reasons: historically, one of the major challenges of retrieving aerosol optical properties in the UV was radiometric calibration, which we suggest a new novel approach for the first time that can be applied to any other UV-VIS-NIR spectrometers (i.e., using the F_{Comb}). In addition, the radiometric calibration results are also essential for understanding the accuracy of the UV aerosol products in the following sections. Therefore, we believe it worth keeping Section 2.3 in the main script. However, we revised the title of Section 2.3. to emphasize this as: "**2.3. A combinative radiometric calibration method for Sun/sky spectroradiometer**".

- iv. Lines 414 and the following paragraph: This seems to serve partially as motivation and partially as a data comparison. In my opinion, the motivation should be split out and described before the measurements.

→ As the referee suggested, the paragraph was moved to the Introduction Section in the revised manuscript.

- b. The organization seems somewhat illogical and there is spurious information given that detracts from the overall data flow.

- i. Lines 163-167: Several comments here:

1. Is lidar data ever used or important?
2. Why describe the DRAGON approach if it is not possible?
3. Are the multiple chemistry samplers named/used?

4. What satellites are you planning to use?
For 1-4 above → The sentences were revised (removed the redundant sentences) as the referee suggested: “As the SMART-s is located in the middle of large source areas of biomass burning during the season, it can provide useful information on carbonaceous aerosols and key trace gases despite its limited spatial coverage.”
 - ii. Lines 168-186: This paragraph seems out of place and unnecessary. Why describe the measurement of dust in the “Experimental Design” section?
→ The sentence was removed from the manuscript as the referee suggested.
 - iii. Lines 382-397, Line 412: background on AERONET seems out of place in the Results section
→ We believe this paragraph can be useful for assessing the comparison result of particle size distribution from the AERONET and SMART-s (Figure 5); both data are retrieved values and need to be compared with more accurate data (e.g., in-situ spiral measurements) as discussed in this section.
 - iv. Lines 414-436: Literature review on n and k within Results section seem out of place. This is the first time it becomes clear how measurements of these parameters can inform the source of aerosol.
→ As the referee suggested, this paragraph was moved to the Introduction section.
 - v. I would suggest a more logical outline for this paper to be:
 1. Introduction
 2. Measurements
 - a. Experimental Design
 - b. Instrument Calibration
 - c. Ancillary Instrumentation
 - i. AERONET
 - ii. ...
 3. Results
 - a. Relationships between aerosols and trace gases
 - b. Comparisons with AERONET
- The authors appreciate the suggestion. However, as we responded to the previous comments, we decided to keep the radiometric calibration section in the main manuscript. According to that decision, we believe the current outline of Section 2 would be appropriate (for including Section 2.3 in the main manuscript).

c. Satellite Algorithms

→ Comparison of the SMART-s retrievals with the AERONET is for validation and checking consistency, which should be demonstrated prior to analysis (i.e., relationship between aerosols and trace gases, and satellite data validation). Therefore, we believe the current outline is more appropriate.

4. Summary

5. Appendix

a. Inversion Algorithm

b. Calibration

c. SMART-s vs AERONET

→ As the referee suggested in the previous comment, we added the trace gas total column retrieval algorithm section in the Appendix.

2. Lines 190-192: That your measurements are unaffected by local emissions seems critical, otherwise you have an uncontrolled bias source of unknown spatial/temporal magnitude causing unknown biases. This sentence therefore needs to be rock solid. I see very little evidence to substantiate this claim that local emissions are negligible, i.e. this sentence doesn't suffice to make that point. Furthermore, it seems to use circular logic that we are seeing mostly biomass burning aerosol, therefore local emissions are negligible, therefore we are ignoring local emissions, therefore we are only seeing biomass burning aerosols.

→ The sentence was revised as follows: *“However, we presume the effects of local emissions from the road to the aerosol and NO₂ amounts are weak given the low level of local traffic and that major fractions of the aerosols and trace gases (e.g., NO₂) during this season are emitted from the biomass-burning over this area (Jena et al., 2015; Itahashi et al., 2018; Khodmanee and Amnuaylojaroen, 2021).”*

3. Line 322-323: I would assume, based on my own past experience not related to the SMART-s sensor, that the SMART-s measurements would be fairly sensitive to intensity of light incident on the sensor, with more light facilitating more precise measurements (up until sensor non-linearity and other non-idealities occur). The information presented in the calibration section seem to support this. I can't help but wonder, therefore, what the difference between thin cirrus and more optically thick plumes would be. Line 633 suggests aerosol optical thicknesses frequently exceeds 2.0. I don't see too much discussion or analysis given to plume optical thickness causing any retrieval issues of any kind. I believe this should be addressed in detail.

→ As the referee suggested, the following paragraph was inserted in the calibration section of the revised manuscript:

“We applied the aerosol retrieval algorithm to the measurements (both direct Sun and solar-almucantar scan) with sufficient amounts of photons within the target spectral range (i.e., from 330 to 800 nm) as very high aerosol loading over the area (e.g., Figure 1b) may result in the low level of voltage counts below the detection limit (e.g., in terms of linearity and noise). Cloud-contaminated direct-Sun spectrums were screened by using their rapid temporal variability and spectral features (i.e., lower Ångström exponent of clouds), which are described in Jeong et al., (2018). Those for the solar-almucantar measurements were removed by checking the horizontal

symmetry of the scan (i.e., between clockwise and counter-clockwise half-circle scans) followed by the AERONET strategy (Jeong et al., 2020)."

4. There are significant English language errors, mostly in the Introduction and Experimental Design section that need to be addressed. I have noted several persistent comments in the "Typos" section below, but this should not be considered an exhaustive list. More accurately, this list is a somewhat halfhearted attempt on my part to highlight this comment but is definitely not all the errors. Given the pervasive nature of the mistakes, it makes the paper difficult to read.

→ We sincerely appreciate the referee's extensive efforts for the precise comments during the revision. As the referee suggested, we reviewed the whole manuscript to make the sentences simpler and more fluent, including all the referee's comments.

5. The referencing in this paper is often good, especially when comparing data from this manuscript to former studies. However, I see 3 major issues that need to be addressed:

a. I count at least 21 instances where the phrase "*and references therein*" is used in lieu of specific referencing. There are two major issues with this in my opinion. First it lacks precision and does not help the reader understand where they should direct their attention to verify or further explore the information presented. Second, this style tends to fail to give credit to those authors whose original findings are cited.

→ We understand the referee's comments. However, we believe such a phrase can be appropriate for general statements by citing review papers such as "*Significant spatiotemporal variabilities of the aerosols in the atmosphere complicate understanding of their scattering and absorption of the solar irradiance, which results in one of the largest uncertainties in predicting future climate (IPCC, 2013; Gliß et al., 2021; Myhre et al., 2013 and references therein).*" We removed the phrase "*and references therein*" where we think is not necessary in the revised manuscript.

b. There are a number of websites included for important information: Line 203: AvaSpec spectrometer, Line 204: Pandonia Global Network, Line 257: Pandonia calibrations, Line 264 for Grande calibration reports, Line 395 for SMARTLabs sensor, Lines 756-757 for data. In general, in my opinion, this is inadequate as websites are very easy to change/remove or simply not update. I believe you need permanent citations, academic literature, or DOIs for this information?

→ We searched for proper references for the citations. However, those (e.g., DOI, overview paper) are not available at this moment. Even though the older publications are outdated to represent the current status of the PGN and RCL, we added permanent citations as the referee suggested below:

"As the Pandonia Global Network (PGN; Herman et al., 2009, 2015; cf. <https://www.pandonia-global-network.org>) is utilizing another type of extended-range spectrometer for their dual-detector system, we refer to this modified Pandora as SMART-s in this study."

"The PGN also regularly reports updates and standard calibration/validation results on their webpage (<https://www.pandonia-global-network.org>; Herman et al., 2009, 2015)."

“More detailed information and annual calibration reports of Grande are available at <https://cf.gsfc.nasa.gov/> or in Gatebe et al. (2007).”

Avantes is a commercial company and does not provide any academic literature, or DOI. However, we updated the citation format as: *“The SMART–s spectrometer is made by the same manufacturer (AvaSpec-ULS2048x64, Avantes, cf. <https://www.avantes.com/> last access on 8 June 2022) as the standard version...”*

c. SMART-s data link (Line 756) redirects to

<https://earth.gsfc.nasa.gov/climate/instruments/smartlabs/> , which gives an overview over SMARTLabs instruments. I could not find data.

→ The SMARTLabs webpage was recently requested by the NASA HQ to ‘modernize’ with the new address. We inserted the updated webpage address as the referee indicated. However, the webpage is not yet capable of sharing data online, and the data are available from the authors Jeong and Tsay. To clarify this, the Section was revised as follows: *“The SMART–s data are also described at <https://earth.gsfc.nasa.gov/climate/instruments/smartlabs/>, and available from the contact email addresses on the webpage. The AERONET data are available at the <https://aeronet.gsfc.nasa.gov> website.”*

As a reviewer, I can not ignore any of these points as they cause a general lack of precision with referencing. To put a very fine point on this comment: the referencing is often inadequate and must be improved.

Minor Comments:

1. In general there are a number of places where redundant information can be omitted for brevity:
 - a. Lines 127-128: “and section 2.2 below” is probably not needed as this is the introduction. I would omit this line.
→ The sentence was revised as the referee suggested.
 - b. Lines 751-753: This sentence should be removed. It is given verbatim in the Code/Data Availability Section below and is not an Acknowledgement.
→ ACP requires the Code/Data availability section; therefore, we removed the repeated sentence in the Acknowledgments as the referee suggested.
 - c. Figure 1: The latitude, longitude, and altitude of the site are given in the text main body. I would remove it from the figure caption to avoid redundancy.
→ We prefer to keep the Figure caption informative and stand-alone, so we removed the information from the main text to avoid redundancy as the referee suggested.
 - d. I would remove color / lineshape information from the text, as that is included within the Figure and captions:
 - i. Line 343 → The sentence was revised as suggested.
 - ii. Line 347 → The sentence was revised as suggested.
 - iii. Line 368 → The sentence was revised as suggested.
 - iv. Line 405 → The sentence was revised as suggested.
 - v. Line 407-408 → The sentence was revised as suggested.
 - vi. Line 471f → The sentence was revised as suggested.
 - vii. Line 528 → The sentence was revised as suggested.
 - viii. Line 532f → The sentence was revised as suggested.
 - ix. Line 547 → The sentence was revised as suggested.
 - x. Line 585f → The sentence was revised as suggested.
 - xi. Line 589f → The sentence was revised as suggested.
 - xii. Line 602 → The sentence was revised as suggested.
 - xiii. Line 604 → The sentence was revised as suggested.
 - e. Redundant information that contains typos and does not agree in the text and Figures:
 - i. Figure 11: caption states AE calculations use e.g. 440 and 555 nm for blue, but in panel (d) it says 440 – 555 nm which suggest the entire range
→ The captions of Figures 11 and 12 were revised as the referee suggested.

- ii. Line 602: values differ from values in Figure
 - Figure 15 in the original manuscript was an older version and was updated in the revised manuscript, which is consistent with the values in the main script.
- iii. Line 604: values differ from values in Figure
 - Figure 15 in the original manuscript was an older version and was updated in the revised manuscript, which is consistent with the values in the main script.
- iv. Line 610: value does not reflect value in Figure
 - Figure 15 in the original manuscript was an older version and was updated in the revised manuscript, which is consistent with the values in the main script.

2. In general, I believe you are well served to always include units after giving numeric values, even if the units are [unitless], it is best to note. I note this in at least the following locations (but please consider this a general pervasive comment that needs to be addressed everywhere):

- a. Line 122: “up to 0.07 at ...”
- b. Line 212: “dynamic range of 107” (is this photon counts, radiance units, or other?)
- c. Line 225: “FWHM ~1.0”
- d. Line 401: “RMSE less than 0.02”

→ In general, we believe it is an unorthodox style approach to place "unitless" after every number without units and makes it more difficult for the reader to comprehend. Further, we do not see any indication on the ACP submission guide about placing unitless after numbers without units.

3. Line 18: Have you omitted the word “resolution” in the phrase “measuring high-spectral _____ ultraviolet”.

→ The sentence was revised as the referee suggested.

4. Line 27: “high spectral resolution” is relative. Please simply provide the resolution here for context.

→ The sentence was revised as the referee suggested.

5. Line 82: What is meant by location vs emission source? Location seems irrelevant in comparison to the source (i.e. biome) type. Additionally, I can believe that w_0 evolves as the plume ages, but don't the others here simply cause w_0 to be different since emission?

→ Identical smoke plumes can age differently under different environmental conditions (e.g., Konovalov et al., 2017); temperature or humidity varies depending on location and season. To clarify this, the sentence was revised as follows:

“Due to the reactivity and diversity of smoke particles, the ω_0 evolves with its environment (i.e., location and season), age, mixing state, and emission source of the plume (e.g., Eck et al., 2013; Haywood et al., 2003; Konovalov et al., 2017).”

6. Line 93: “acceptable agreement” lacks clarity and precision. Suggest modifying this to be quantitative.

→ The sentence was revised as the referee suggested:

“Pistone et al. (2019) compared the spectral ω_0 of smoke aerosols from six independent airborne- and ground-based remote-sensing/in-situ instruments in September of 2016 out of Walvis Bay, Namibia, which showed acceptable agreements within the known uncertainties of each instrument (relative differences less than about 0.03 in mid-visible and less than about 0.05 in near-infrared, depends on the instruments).”

7. Line 131-132: “which are yet lack of sufficient reliable measurements” makes no sense. Perhaps change to “for which reliable measurements remain sparse”.

→ We appreciate the referee for the comment. The sentence was revised as the referee suggested.

8. Line 154: In my opinion, this sentence is more of an “Experimental Setup” than “Experimental Design”. Suggest changing the title.

→ The title was revised as the referee suggested.

9. Lines 155-157: This sentence seems to be an attempt to be general but needs serious revision, or deletion. In general, I believe it is saying that the best match to spaceborne spectrometer data is ground based spectrometer data. This is fairly obvious. However, that spaceborne or ground based spectrometer data are the best representation of the state of the atmosphere is highly dependent on the properties of the atmosphere. My suggestion is to simply delete this sentence. At the very least, the words temporal, spectral, angular, and spatial describe observed dimensions with passive remote sensing equipment and not “fundamental elements”.

→ The whole sentence was revised considering the referee’s comments:

“The ground-based spectroradiometer observations have offered optimum inversion products of the atmosphere for validating/comparing those from collocated space-borne sensors; these are less affected by the surface reflectance and can acquire more informative products from their higher resolution of temporal, spectral (including polarization), and angular measurements.”

10. Lines 157-159: This sentence is almost unintelligible.

a. What are collocated satellites?

b. b. “in-situ representation of measurements” seems backwards. In-situ measurements should be improved to better represent the state of the atmosphere.

c. c. Are you just trying to say you are more broadly deploying sensors in the DRAGON network?

→ The whole sentence was revised considering the referee's comments:

"In addition, strategically networked ground-based instruments (e.g., Distributed Regional Aerosol Gridded Observation Networks or DRAGON; Holben et al., 2018) can supplement their limited spatial representation."

11. Line 160: suggest changing "northern Thailand of Chiang" to "northern Thailand, specifically the Chiang".

→ We appreciate the referee for the comment. The sentence was revised as the referee suggested.

12. Line 196f: Are measurements and data analysis restricted to the daytime?

→ Yes, because the algorithm uses direct and scattered solar intensity measurements.

13. Lines 213-215: Is this a mistake that inserting the diffuser alters the instrument field of view? Does the diffuser have optical power (i.e. does it have a focal length smaller than infinity)? I am assuming the field stop is the optical fiber that transfers light from the scanning head to the spectrometer, which I am also assuming doesn't change with or without the diffuser. I could easily believe that the diffuser acts as an aperture stop but that seems weird that it would alter the field of view.

→ The diffuser was added to improve the quality of the direct sun measurements, so the light is distributed homogeneously on the surface of the fiber (this is why the diffuser is only used for the sun measurements, not the sky), no angular effects and mostly flat FOV top. The FOVs for different filters (open, diffuser, etc) are measured by scanning solar aureole angles with a 0.1° resolution). See the below figure for more details about the sensor head.

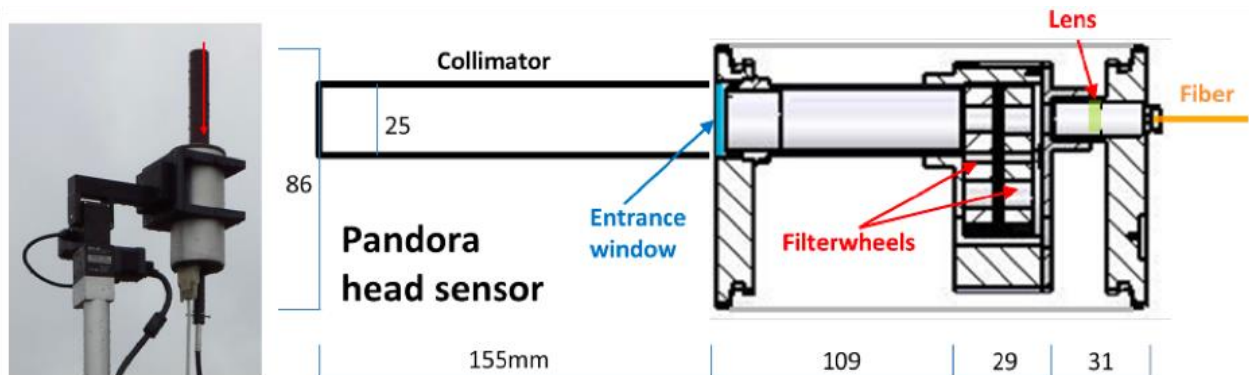

14. Line 215: suggest changing "secure more photons reaching" to "allow more photons to reach".

→ We appreciate the referee for the comment. The sentence was revised as the referee suggested.

15. Line 216: "fiber-optic cable in" should be "fiber-optic cable with a".

→ The sentence was revised as follows:

“The optical head is mounted on a Sun/sky-scanner and is connected to the spectrometer through a fiber-optic cable of 400 μm in diameter.”

16. Line 217: What temperature is it cooled to? Is the temperature monitored?

→ The controlled temperature depends on ambient temperature due to the capacity of the thermoelectric cooler. The temperature is monitored for each measurement. The following sentence was inserted to elaborate on this:

“The spectrometer is thermoelectrically controlled to maintain a near-constant temperature but may vary slightly depending on the ambient temperature (typically less than 1°C). The spectrometer temperature is recorded with each measurement to monitor data quality..”

17. Line 240: “for whole wavelengths” should probably be “for all wavelengths”.

→ The sentence was revised as the referee suggested.

18. Line 243: SMART-s uncertainty should be cited. If that citation is intended to be the Jeong et al. 2018 paper, it should be moved forward in the sentence as the sentence really puts forth 2 ideas: uncertainty and the source of the uncertainty.

→ As the referee suggested, the sentence was revised as follows:

“Note that the uncertainty of τ_{aer} from the SMART-s (~ 0.02 in the VIS-NIR, ~ 0.03 in the UV) is slightly higher than the AERONET (~ 0.01 in the VIS-NIR, ~ 0.02 in the UV) due to the wider FOV (Jeong et al., 2018), which is more susceptible to forward scattering, and temperature sensitivity of the detector (Kinne et al., 1997).”

19. Line 247: Below 50 degree in terms of zenith or elevation?

→ As the referee suggested, the sentence was revised as follows:

“The recent version of instruments added hybrid sky-scan measurements to allow additional retrievals at solar zenith angle (θ_s) below 50°.”

20. Line 268: “levels of light output” sounds odd and lacks precision. Are you describing increased intensity, irradiance, radiance, fluence, or something else entirely?

→ As the referee suggested, the sentence was revised as follows:

“Different colors in Figures 2b and 2c indicate the different levels of Grande intensity.”

21. Line 268-270: This sentence describing the reduced calibration uncertainty with increasing intensity makes sense to me. It does not explain the most noticeable feature of the plot, at least in my opinion, which seems to be the significant increase in uncertainty around 330 nm. There is only a small figure caption footnote here to explain, which I think should be expanded. As this wavelength is used somewhat often, I believe you should describe the mechanism causing this uncertainty more clearly in your main text.

→ As the referee suggested, the following sentences were inserted in the revised manuscript:

“During the light source calibration, the sensor changed its filter (UV band-pass) to detect the lower intensity of the Grande in the UV which results in the relatively higher uncertainties near

350 nm (see Figure 2c). Note that the measurement error covariance matrix of the OEM also accounts for such spectral radiometric uncertainties (see Appendix B and Jeong et al., 2020)."

22. Line 274-275: "wired the cable differently" lacks precision. Are you simply reseating the cable in its mount or inserting elements or rerouting the cable or something else?

→ As the referee suggested, the sentence was revised as follows:

"For checking the stability of the fiber-optic cable during deployment, we oriented the cable differently (i.e., re-rolled the cable every time with different diameters or arbitrarily oriented it), then reconnected the ports to the spectrometer at each time of the Grande measurements."

23. Line 296: Unclear whether it is a second detector or the identical detector used to measure the solar irradiance.

→ As the referee suggested, the sentence was revised as follows:

"Although ground-based instruments also measure the solar light using an identical detector as for the sky radiances, they sample the solar irradiance after it passed through the atmosphere. For that reason, their algorithms utilize other sources of the solar spectrum or estimate it from the measurements for the conversion of the sky radiances."

24. Line 339f: This is unclear to me. The UV region remains susceptible to stray light influences despite the OOB stray light correction?

→ The sentence means that even with the OOB straylight correction algorithm, the remaining portion of the OOB straylight can still be significant due to the limited number of photons in the deeper UV. To clarify this, we updated the sentence in the revised manuscript as:

"Despite the Sun/sky measurements undergoing empirical OOB stray light correction (Jeong et al., 2018), the remaining fraction may still be nonnegligible in the shorter wavelengths of UV (particularly wavelengths shorter than about 330 nm; see Figure 7c of Jeong et al., 2018)."

25. Line 364: Is this the first place where RMSE and MBE (Root Mean Square Error and Mean Bias Error) are used? If so, the acronyms should be defined here in the main text (not on line 401) and not in the Figure caption

→ Thanks for the correction. The sentence was corrected in the revised manuscript as the referee suggested.

26. Lines 366-67: the phrase "—utilization of individually own measurements with different instrumental characteristics" makes no sense to me. My suggestion is simply to omit it as the sentence stands alone without the additional clarification.

→ As stated in the previous sentences, Jeong et al. (2020) applied the SMART-s algorithm to the AERONET Sun/sky measurements for two reasons: 1) to check algorithm consistency (same measurements but different algorithm), 2) lack of radiometrically calibrated SMART-s measurements at that moment. This study applied each algorithm to their own measurements as now we have the radiometrically calibrated SMART-s data. Thus, we believe it is worth noting the difference, but we clarified the sentence as follows:

"In this section, we performed additional comparisons of aerosol property retrievals from SMART-s to those from collocated AERONET by utilizing their own measurements."

27. Line 368f: Mention of non-negligible portions of the aerosols being from e.g. desert dust. How exactly is that determined which aerosol makes up which source quantities? What percentage is desert dust to be claimed as non-negligible in comparison to other sources? → It can be inferred from the Volume-size distribution ($V(r)$) in Figure 5, which consists of a major fraction of fine-mode and a minor fraction of coarse-mode. Compared to fine-mode predominated cases (e.g., see Figure 11 in Eck et al., 2003; <https://doi.org/10.1029/2003GL017861>), the coarse-mode volume fraction is not negligible in Figure 5; but is insignificant in coarse mode concentration compared to dust dominated locations (Eck 2010: <https://agupubs.onlinelibrary.wiley.com/doi/full/10.1029/2010JD014002>). The fraction (percentage) depends on which definition we use (e.g., volume, surface, number, mass), but the $V(r)$ is one of the effective parameters to assess fine- and coarse mode contributions as in Figure 5.

28. Line 371: “which is in general consistency” should be “which is generally consistent”. → The manuscript was revised as the referee suggested.

29. Line 371: “agreements” should be “agreement” as it is referencing the plural “ $V(r)$ s”. → The manuscript was revised as the referee suggested.

30. Lines 414-436: This information is summarized in Table 1. However, it is not mentioned until the paragraph below. Suggest mentioning Table 1 up front for your readers’ reference. → The manuscript was revised as the referee suggested.

31. Line 512f: Are you trying to say w_0 from 330nm correlates better with H₂O than w_0 from 550nm with H₂O? This sentence is unclear as it starts with “ w_0 and H₂O are correlated” but then speaks of “temporal trends for w_0 ”. → For clarity, the sentence was revised as the referee indicated: “Interestingly, the correlation between the ω_0 and H₂O was even higher ($R = 0.81$ for ω_0 at 330 nm) than their temporal trends as shown in this figure.”

32. Figure 11-12: The in-figure text sometimes overlaps your data. I would suggest putting the blue and red text next to each other instead of stacking it. I would also put the letters defining the panel in a consistent spot. → Figures 11 and 12 were updated as the referee suggested.

33. Figure A1: What is the difference between the data shown in black (in the foreground of the image) and red (a few points in the background of the image)? Do the statistics only account for the black data? → The plot was black open circles filled with red, and it looked black when many plots overlap. The figure (A1 and A2) was updated with the simple black circle for clarity. Thanks for the comment.

Typos:

1. In general, the addition of an article is needed in a number of places:
 - a. Line 50: “Dominant fraction” should be “The dominant fraction” → [Corrected](#)
 - b. Line 58: “sphere” should be “a spherical” → [Corrected](#)
 - c. Line 94: “Over Southeast Asia series of” should be “Over Southeast Asia a series of” → [Corrected](#)
 - d. Line 102: “Majority” should be “A majority” → [Corrected](#)
 - e. Line 112: “a wavelength-independent” → [Corrected](#)
 - f. Line 113: “Krotkov et al. used aerosol” should be “Krotkov et al. used the aerosol” or “Krotkov et al. used an aerosol” → [Corrected](#)
 - g. Line 117: “SKYNET instrument” should be “A SKYNET instrument” → [Corrected](#)
 - h. Line 189: “Population of” should be “The population of” → [Corrected](#)
 - i. Line 202: “is made by same” should be “is made by the same” → [Corrected](#)
 - j. Line 203: “but covers wider” should be “but covers a wider” → [Corrected](#)
 - k. Line 212-213: “sky-scans using single” should be “sky-scans using a single” → [Corrected](#)
 - l. Line 236: “operate global network” should be “operate a global network” → [Corrected](#)
 - m. Line 244: “temperature sensitivity of detector” should be “temperature sensitivity of the detector” → [Corrected](#)
 - n. Line 245: “Current AERONET” should be “The current AERONET...” → [Corrected](#)
 - o. Line 246: “it can add 380” should be “it can add a 380” or “it can add the 380” → [Corrected](#)
 - p. Line 301: “derives conversion factor” should be “derives a conversion factor”, and “based on solid-view-angle estimation algorithm” should be “based on the solid-view-angle estimation algorithm” → [Corrected](#)
 - q. Line 302: “combination of” should be “a combination of” → [Corrected](#)
 - r. Line 310: “sky-measurement” should be “a sky-scan measurement”, and “detector to radiance” should be “the detector to the radiance” → [Corrected](#)
 - s. Line 311: “instrument’s” should be “the instrument’s” → [Corrected](#)
 - t. Line 315: “direct-Sun measurement” should be “the direct-Sun measurement” → [Corrected](#)
 - u. Line 333: “spectral mean” should be “the spectral mean”, and “traditional method” should be “the traditional method”, and “high-resolution” should be “a high-resolution” → [Corrected](#)
 - v. Line 334: “instrument’s” should be “the instrument’s” → [Corrected](#)
 - w. Line 335: “is final solar irradiance for SMART-s algorithm” should be “is the final solar irradiance for the SMART-s algorithm” → [Corrected](#)
 - x. Line 336: “near to middle” should be “near to the middle” → [Corrected](#)
 - y. Line 338: “spectral shape” should be “the spectral shape” → [Corrected](#)
 - z. Line 345: “wavelength node” should be “the wavelength node” → [Corrected](#)
 - aa. Line 353: “total error” should be “the total error” → [Corrected](#)
 - bb. Line 355: “solar spectrum” should be “the solar spectrum” → [Corrected](#)
 - cc. Line 361: “optically effective range” should be “the optically effective range” → [Corrected](#)
 - dd. Line 362: “assumes bi-modal” should be “assumes a bi-modal” → [Corrected](#)
 - ee. Line 387: “at higher” should be “at a higher” → [Corrected](#)
 - ff. Line 423-424: “based on optical trapping method” should be “based on the optical trapping method” → [Corrected](#)
 - gg. Line 518: “did not show meaningful” should be “did not show a meaningful” → [Corrected](#)
 - hh. Line 530: “show relationship” should be “show the relationship” → [Corrected](#)
 - ii. Line 533: “proportional relationship” should be “a proportional relationship” → [Corrected](#)

- jj. Line 535: “following equations” should be “the following equations” and “radius” should be “radii” → [Corrected](#)
- kk. Line 550: “information on degree” should be “information on the degree” → [Corrected](#)
- ll. Line 556, 557: “showed negative correlation” should be “showed a negative correlation” and “positive correlation” should be “a positive correlation” → [Corrected](#)
- mm. Line 563: “suggest potential benefit” should be “suggest the potential benefit”, and “measure” should be “measurements” → [Corrected](#)
- nn. Line 578: “ASHE algorithm” should be “the ASHE algorithm” → [Corrected](#)
- oo. Line 650: “during limited” should be “during a limited” → [Corrected](#)

2. A number of simple phrases seem odd to me. To read more naturally, I would suggest:

- a. Line 74: “complement their limitations” should perhaps be “expand upon their limitations”? → [Corrected](#)
 - b. Lines 90-91: “15 years of period” should be “a 15-year period” → [Corrected](#)
 - c. Line 103: “as discrete” should be “in discrete” or “within discrete” → [Corrected](#)
 - d. Line 104: “at each” should be “per” → [Corrected](#)
 - e. Line 110: “To take account for” should just be “To account for” → [Corrected](#)
 - f. Line 117: “with the AERONET” should be “within the AERONET” → [Corrected](#)
 - g. Line 131f: Suggest “which yet lack sufficient reliable measurements”, i.e. remove “are” and “of” → [Corrected](#)
 - h. Line 162: “in rotary-/fixed-wing of ~130 flights” should be “in a rotary-/fixed wing configuration for ~130 flights” → [Corrected](#)
 - i. Line 193: “started since 8 March 2019” should be “started on 8 March 2019” → [Corrected](#)
 - j. Line 206: “we refer this modified” should be “we refer to this modified” → [Corrected](#)
 - k. Line 212: “it can measure radiances” (plural) → [Corrected](#)
 - l. Line 216: “fiber-optic cable with 400 um diameter” or “fiber-optic cable 400 um in diameter” → [Corrected](#)
 - m. Line 234: Suggest “are in the study, key characteristics are included here in Appendix B.” → [Corrected](#)
 - n. Line 248: Suggest either “adopts monthly climatologies” or “adopts a monthly climatology” → [Corrected](#)
 - o. Line 268: changing “UV than in the” to “UV compared to the” → [Corrected](#)
 - p. Line 298: change “solar light after passed” to “solar light after it passed” → [Corrected](#)
 - q. Line 452: “is yet challenging” should be “remains challenging” → [Corrected](#)
 - r. Line 453: “for the Figure 5” should just be “for Figure 5” → [Corrected](#)
 - s. Line 515: the insertion of “rather” into “to more smoldering rather than flaming” would make this sentence read more smoothly → [Corrected](#)
 - t. Line 633: changing “significantly large” to “frequently large” or something similar → [Corrected](#)
 - u. Line 648: “which supposed to” should be “which is supposed to” → [Corrected](#)
3. Line 79: I believe the comma after “Particularly,” should be omitted → [Corrected](#)
4. Line 97: I believe “aerosols are analyzed” should be “aerosols were analyzed” as all the references are at least 6 years old → [Corrected](#)
5. Line 107: “Collocated AERONET” should be “Collocated AERONET instruments” → [Corrected](#)

6. Line 107: “Peters” should be “Petters” → [Corrected](#)
7. Line 111: Should there be a subscript “aer” for tau? → [Corrected](#)
8. Line 114: Suggest removing “the” prior to “n at 440 nm” → [Corrected](#)
9. Line 118: “SKYNET instrument is” should be “SKYNET instruments are” → [Corrected](#)
10. Line 131f: Suggest “which yet lack sufficient reliable measurements”, i.e. remove “are” and “of” → [Corrected](#)
11. Line 161: “Systems” should be “system” or “a” should be something like “several” → [Corrected](#)
12. Line 161: I believe your parenthetical ends after System, i.e. “sUAS (small Unmanned Arial System)” → [Corrected](#)
13. Line 163-164: “one SMART-s instruments” should be “one SMART-s instrument” → [Corrected](#)
14. Line 187: AERONET is not an instrument but a collection of them. Therefore, “and AERONET are” should be “and AERONET instrument are” → [Corrected](#)
15. Line 192: Omit the “at” in the phrase “Chotana road shown at behind” → [Corrected](#)
16. Line 195: “AERONET is installed at the” should be “AERONET instrument is installed on the” → [Corrected](#)
17. Line 214: “Sky observations does” should be “Sky observations do” → [Corrected](#)
18. Line 311: “radiometer” should be “radiometer’s” → [Corrected](#)
19. Line 339: “undergo” should be “undergoing” → [Corrected](#)
20. Line 340: “Fcomb supposed” should be “Fcomb is supposed” → [Corrected](#)
21. Line 346: should be plural, “absorption bands” → [Corrected](#)
22. Line 354: Usually Vis was all capital letters → [Corrected](#)
23. Line 361: Should “radius nodes” be “radiance nodes”? → [It is radius nodes of the particle size distribution retrieval.](#)
24. Line 371: “consistency” should be “consistent” → [Corrected](#)
25. Line 447: remove “(subscript f for fine-mode and c for coarse-mode)”, already clear from Line 437 → [Corrected](#)
26. Line 496: Should “adsorption” be “absorption”? → [Corrected](#)
27. Line 511f: Should e.g. “decreased” be added to this sentence to read: “H2O gradually increased as biomass-burning activities decreased approaching toward the monsoon season” → [Corrected](#)
28. Line 571: “from observations by the CALIOP” should probably be “from observations by CALIOP” to match the treatment above by the other satellite sensors. → [Corrected](#)
29. Line 745: “Authors of Jeong/Tsay” should be “Authors Jeong/Tsay” → [Corrected](#)
30. Figure 8: Should there be a label for panel (b)? → [Corrected](#)