

1 **Hygroscopicity of organic surrogate compounds from**
2 **biomass burning and their effect on the efflorescence of**
3 **ammonium sulfate in mixed aerosol particles**

4 Ting Lei^{1,2}, Andreas Zuend⁴, Yafang Cheng^{2,3}, Hang Su^{2,3}, Weigang Wang¹, Maofa Ge^{1*}

5 ¹State Key Laboratory for Structural Chemistry of Unstable and Stable Species, CAS
6 Research/Education Center for Excellence in Molecular Sciences, Institute of Chemistry, Chinese
7 Academy of Sciences, Beijing, 100190, P. R. China

8 ²Multiphase Department, Max Planck Institute for Chemistry, Mainz 55128, Germany

9 ³Institute for Environmental and Climate Research, Jinan University, Guangzhou, China

10 ⁴Department of Atmospheric and Oceanic Sciences, McGill University, Montreal, Quebec, Canada

11 *Correspondence to:* M. F. Ge (gemaofa@iccas.ac.cn)

12

13 **Abstract:** Hygroscopic growth factors of organic surrogate compounds representing biomass burning
14 and mixed organic-inorganic aerosol particles exhibit variability during dehydration experiments
15 depending on their chemical composition, which we observed using a hygroscopicity tandem differential
16 mobility analyzer (HTDMA). We observed that levoglucosan and humic acid aerosol particles release
17 water upon dehumidification in the range from 90 – 5 % relative humidity (RH). 4-Hydroxybenzoic acid
18 aerosol particles, however, remain in the solid state both upon dehumidification or dehumidification and
19 exhibit a small shrinking in size at higher RH compared to the dry size. For example, the measured
20 growth factor of 4-hydroxybenzoic acid aerosol particles is ~0.96 at 90 % RH. The measurements were
21 accompanied by RH-dependent thermodynamic equilibrium calculations using the AIOMFAC and the
22 E-AIM models, the ZSR relation, and a fitted hygroscopicity expression. We observed several effects of
23 organic components on the hygroscopicity behavior of mixtures containing ammonium sulfate (AS) in
24 relation to the different mass fractions of organic compounds: (1) a shift of efflorescence relative
25 humidity (ERH) of ammonium sulfate to higher RH due to the presence of 25 wt % levoglucosan in the
26 mixture. (2) There is a distinct efflorescence transition at 25 % RH for mixtures consisting of 25 wt % of
27 4-hydroxybenzoic acid compared to the ERH at 35 % for organic-free AS particles. (3) There is indication
28 for a liquid-to-solid phase transition of 4-hydroxybenzoic acid in the mixed particles during dehydration.

29 (4) A humic acid component shows no significant effect on the efflorescence of AS in mixed aerosol
30 particles. In addition, consideration of a composition-dependent degree of dissolution of crystallization
31 AS (solid-liquid equilibrium) in the AIOMFAC and E-AIM models leads to a relatively good agreement
32 between models and observed growth factors, as well as ERH of AS in the mixed system. The use of the
33 ZSR relation leads to good agreement with measured diameter growth factors of aerosol particles
34 containing humic acid and ammonium sulfate. Lastly, two distinct mixtures of organic surrogate
35 compounds, including levoglucosan, 4-hydroxybenzoic acid, and humic acid were used to represent the
36 average water-soluble organic carbon (WSOC) fractions observed during the wet and dry seasons in the
37 central Amazon Basin. A comparison of the organic fraction's hygroscopicity parameter for the simple
38 mixtures, e.g. $\kappa \approx 0.12$ to 0.15 for the wet-season mixture in the 90 % to 40 % RH range, shows good
39 agreement with field data for the wet season in Amazon (WSOC $\kappa \approx 0.14 \pm 0.06$ at 90 % RH). This
40 suggests that laboratory-generated mixtures containing organic surrogate compounds and ammonium
41 sulfate can be used to mimic, in a simplified manner, the chemical composition of ambient aerosols from
42 the Amazon for the purpose of RH-dependent hygroscopicity studies.

43 **Introduction**

44 It is well established that biomass burning, as an important source of atmospheric aerosol particles, has
45 a wide range of climate effects that can be classified into direct radiative effects through light-absorbing
46 carbon aerosol particles and indirect effects by impact on cloud condensation nuclei and cloud
47 microphysics (Andreae and Gelencsér, 2006; Moosmüller et al., 2009; Hecobian et al., 2010; Rizzo et
48 al., 2011; Rose et al., 2011; Cheng et al., 2012; Engelhart et al., 2012; Lack et al., 2012; Jacobson, 2014;
49 Liu et al., 2014; Saleh et al., 2013, 2014). Atmospheric light-absorbing particles that arise from biomass
50 burning play an important role as a driver of global warming (Favez et al., 2009; Hegg et al., 2010; Lack
51 et al., 2012; Feng et al., 2013; Laborde et al., 2013; Srinivas and Sarin, 2013). According to the IPCC
52 report (Boucher and David, 2013), the climate forcing of black carbon aerosol particles may rival that of
53 methane, with a present-day global warming effect of up to $0.3\text{--}0.4$ °C (Wang et al., 2014). Also, certain
54 types of aerosol particles emitted by biomass burning, when immersed into cloud droplets, absorb solar
55 radiation and facilitate water evaporation and cloud dispersion, which indicates an additional indirect
56 aerosol effect that counteracts the cooling effect of cloud droplets nucleated by aerosols (Powelson et al.,
57 2014). Therefore, a better understanding of the influence of aerosol particles from biomass burning on

58 cloud formation, precipitation, and Earth's radiative budget is required to comprehend biomass burning
59 aerosol properties and behavior.

60 The understanding of aerosol-cloud-climate impact of a vast range of biomass burning derived organic
61 compounds, however, is rather limited due to the complexity of biomass burning emissions, gas- and
62 aerosol-phase processing and the restricted availability of field measurements (Pratt et al., 2011; Lei et
63 al., 2014; Paglione et al., 2014; Srinivas and Sarin, 2014; Zhong and Jang, 2014; Ciarelli et al., 2015;
64 Arnold et al., 2015; Lawson et al., 2015; Gilman et al., 2015). Moreover, biomass burning particles are
65 often mixtures of water-soluble organic carbon, black carbon, varying amounts of inorganic components,
66 and water insoluble inclusions, such as mineral dust or poorly soluble organics (Väkevä et al., 2002;
67 Sadezky et al., 2005; Saarnio et al., 2010). An appreciable amount of organic compounds affect the
68 physicochemical properties of aerosols, such as hygroscopicity, liquid-solid and liquid-liquid phase
69 transitions, and chemical reactivity in liquid phases and/or on particle surfaces (Shiraiwa et al., 2013).
70 For example, equilibrium between the variable environmental water vapor mixing ratio and aerosol
71 particles may lead to substantial changes in particle size, and chemical composition, all of which can
72 influence light absorption and scattering (Seinfeld and Pandis, 2006; Zhang et al., 2016). RH-dependent
73 transitions between solid and liquid (aqueous) phases are also important in determining optical properties
74 (Martin et al., 2013; Wang et al., 2010; Kim et al., 2016; Wu et al., Denjean et al., 2015; 2016; Hodas et
75 al., 2015; Atkinson et al., 2015). Studies have shown that water-soluble organic matter from biomass
76 burning (approximately 70 % of total organic matter) can significantly suppress, enhance or have no
77 effect on the deliquescence (e.g. the RH at which deliquescence occurs at a certain temperature, the DRH)
78 and efflorescence process (e.g. the efflorescence RH, ERH) of present inorganic electrolytes. The effect
79 depends predominantly on the type of organics, mass fraction of organics relative to inorganic, and
80 particle size (You and Bertram, 2014; Zawadowicz et al., 2015; Hodas et al., 2015; Gupta et al., 2015).
81 Whole particles, individual phases within particles, or specific chemical compounds can undergo a range
82 of phase transitions including crystallization/efflorescence, dissolution/deliquescence, and liquid-liquid
83 phase separation as the relative humidity varies in the atmosphere. A number of laboratory studies have
84 focused on liquid-liquid phase separations within particles consisting of inorganic and organics fractions
85 (Svenningsson et al., 2006; Carrico et al., 2008; Dusek et al., 2011; Hodas et al., 2015). For example,
86 studies about liquid-liquid separation occurring in mixed organic-inorganic aerosols were performed by

87 Song et al. (2012, 2013) and You et al. (2013) using Raman and optical microscopy, establishing that
88 liquid-liquid phase separation occurs typically in mixed organics + ammonium sulfate particles with an
89 average elemental oxygen-to-carbon (O:C) ratio of the organic fraction of less than 0.6 and in some cases
90 for $0.6 < \text{O:C} < 0.8$. You et al. (2013) further found that for a O:C ratio between 0.5 and 0.8, the
91 occurrence of liquid-liquid phase separation at moderate to high RH depends on the types of inorganic
92 salts present (i.e., the effective strength of the salting-out effect), e.g., $(\text{NH}_4)_2\text{SO}_4 \geq \text{NH}_4\text{HSO}_4 \geq \text{NaCl} \geq$
93 NH_4NO_3 . Recently, the effect of a potential size-dependent morphology and dependence of the phase
94 separation mechanism on the organic/inorganic mass ratio in mixed aerosol was studied for mixtures of
95 poly- (ethylene glycol)-400 + ammonium sulfate using cryogenic-transmission electron microscopy
96 (Altaf et al., 2016). Therefore, many independent studies suggest that the occurrence of solid-liquid
97 and/or liquid-liquid phase separations, as well as related (temperature-dependent) RH levels of phase
98 transitions (DRH, ERH, SRH), depend on the relative amounts of organic and inorganic aerosols
99 components and their non-ideal mixing behavior.

100 The expected physical state and morphology of aerosol particles containing mixtures of a wide range
101 of organic and inorganic salts/acids can, in principle, be predicted by a selection of specialized
102 thermodynamic equilibrium models. Such models include the Extended Aerosol Inorganic Model (E-
103 AIM) (Clegg and Seinfeld, 1998, 2006; available online: <http://www.aim.env.uea.ac.uk/aim/aim.php>),
104 the Aerosol Diameter Dependent Equilibrium Model (ADDEM) (Topping et al., 2004), the UNiversal
105 Quasichemical Functional Group Activity Coefficients model (UNIFAC) (Fredenslund et al., 1975;
106 Hansen et al., 1991), and the Aerosol Inorganic-Organic Mixtures Functional groups Activity
107 Coefficients model (AIOMFAC) (Zuend et al., 2008, 2011, 2012). These models have all been used to
108 predict atmospheric aerosol thermodynamic equilibrium for a variety of inorganic and organic systems,
109 yet not all of them can be used to compute non-ideal mixing in organic-inorganic systems. AIOMFAC
110 has been used to predict the distribution of components in multiple phases in a range of mixed organic-
111 inorganic systems and demonstrated its broad applicability in predicting liquid-liquid phase separation
112 in such mixtures (Zuend et al., 2010; Song et al., 2012; Zuend and Seinfeld, 2012; Shiraiwa et al., 2013;
113 Renbaum-Woff et al., 2016; Rastak et al., 2017).

114 Several previous experimental studies using the HTDMA technique (e.g. Zardini et al., 2008; Lei et
115 al. 2014) show that the deliquescence of inorganic compounds is affected by the presence of organic

116 components, which manifests itself in a shift in the DRH of a salt compared to the corresponding organic-
117 free system. For instance, a clear shift of ammonium sulfate DRH was observed in the case of the
118 levoglucosan + ammonium sulfate system (Lei et al., 2014). Here we focus on investigating the
119 morphology, hygroscopicity and phase transitions of relevant organic compounds found in biomass
120 burning aerosol during the dehydration/dehumidification process. Moreover, we study how the presence
121 of organic compounds affects the water loss behavior of mixed organic-inorganic aerosols with
122 ammonium sulfate (AS) in the supersaturated state as well as after efflorescence of AS. In addition, we
123 compare the measured hygroscopicity behavior of mixed aerosol particles with predictions from the
124 Zdanovskii–Stokes–Robinson (ZSR) mixing rule, the E-AIM model and the AIOMFAC model.

125

126 **2 Methods**

127 **2.1 Aerosol system**

128 The three organic compounds levoglucosan, 4-hydroxybenzoic acid and humic acid were used as
129 surrogates for the rich-class of water-soluble organic components in biomass burning aerosols. The
130 influence of the distinct chemical structure of these compounds was studied with regard to the water
131 uptake and evaporation of the pure organic compounds as well as for mixed organic-AS-containing
132 particles. Furthermore, a comparison with field data from the Amazon was performed to quantify the
133 ability of mixtures of these three organic compounds to mimicking the hygroscopic behavior of complex
134 ambient organic particles originating from biomass burning emissions. Here we focus on the
135 characterization of hygroscopic growth factors as well as solid-liquid and liquid-liquid phase transitions
136 during the dehumidification conditions. The chemical substances and their physical properties are
137 characterized in Table 1. All of the experimental solutions were prepared by dissolving in Milli-Q water
138 (resistivity $\geq 18.2 \text{ M}\Omega$) and the experiments were conducted at room temperature ($\sim 298 \text{ K}$). For the
139 mixtures of ammonium sulfate and organic surrogates the different mass ratios of AS: organic considered
140 are 3:1, 1:1 1:3. The chemical compositions of biomass-burning model mixtures are introduced in Table
141 2.

142 **2.2 Instrument design**

143 Figure 1 shows a schematic of the HTDMA instrument, more detailed information about this instrument's
144 setup, calibration and evaluation is described elsewhere (Lei et al., 2014; Jing et al., 2015, 2017; Liu et
145 al., 2015). Briefly, Poly-dispersed sub-micrometer aerosol particles are generated by atomizing (MSP
146 1500, MSP) a 0.05 weight % aqueous solution consisting of different mass fractions of inorganic, and
147 organic components, assuming that the composition of the formed aerosol particles is initially the same
148 as that of the solution used in the atomizer. Aerosol particles from an atomizer are routed through
149 homemade silica diffusion dryers and then pass through a Nafion gas dryer (Perma Pure Inc., USA).
150 After aerosol particles were dried to below 5 % RH (RH set point 1, RH1), they are directed to the
151 impactor; those aerosols with diameter less than 1 μm are allowed to pass it and subsequently pass
152 through a ^{85}Kr electric charger to reach a near-Boltzmann distribution of charges (Liu et al., 1985). After
153 charging, the aerosol particles enter the first differential mobility analyzer (DMA1) at a sheath flow to
154 aerosol flow ratio of 4:0.3. The sheath flow is circulated by the diaphragm pump in the first loop DMA1
155 system, and its RH is kept constant at below 5 % RH. The resulting mono-disperse particle population,
156 selected within uncertainty by the DMA1, is then exposed to high RH conditions during which the aerosol
157 flow is humidified to 98 % RH by mixing water through a Nafion membrane humidifier at 30 °C. After
158 passing through a saturator (Perma Pure Inc., USA), the aerosols are dried to a target RH level (RH2)
159 through a series of two single-Nafion tubes (Perma Pure Inc., USA) with RH2 set to a value in the range
160 of 90 % to 5 % RH. Here, a pulse width modulator (PWM) circuit is used to regulate the sheath flow on
161 the basis of a proportional integral derivative (PID) system. When the second Nafion membranes allow
162 for regulating the sheath flow to a desired RH and for controlled flow into the sample stream until the
163 RH2 setting value is equal to the excess RH of sheath flow value (RH3), the mobility diameter of the
164 dehumidified aerosols at target RH are measured with the second DMA (DMA2, a scanning DMA)
165 coupled with a condensation particle counter CPC (Model 1500, MSP). In addition, the residence time
166 between the humidifier and DMA2 is around 5 s, which is estimated to be sufficient for aerosols to grow
167 /shrink to equilibrium size at a certain RH setpoint. Also, due to recirculation of the sheath flow and the
168 pre-humidification of the aerosol flow, the sheath flow and aerosol sample flow are enabled to rapidly
169 reach the same RH.

170 **2.3 Theory and modeling methods**

171 Models were applied to explore the extent to which measured hygroscopic diameter growth factors

172 (HGFs), particle phase states, and phase compositions under sub-saturation conditions can be predicted
173 by thermodynamic equilibrium models. For the AS-containing systems studies, the current
174 thermodynamic equilibrium predictions account for a crystalline AS phase with solid-liquid equilibria
175 prior to the complete deliquescence of AS under hydration conditions. Similarly, the crystallization point
176 followed by a solid-liquid equilibrium of AS needs to be considered to predict the effect of organic
177 components in the mixed particles on the shift/suppression of AS efflorescence during aerosol
178 dehumidification, i.e. referring to processes occurring along the dehydration branch of a HTDMA
179 humidification-dehumidification cycle. The calculation of the ERH of AS in an organic-inorganic
180 solution is thermodynamically related to the solubility limit, but it is not strictly deterministic (unlike the
181 DRH) due to the stochastic nature of nucleation-and-growth of a crystal embryo. The molality of pure
182 AS at saturation in an aqueous solution is known, e.g. measured by Apelblat (1993) at 298.15 K as
183 $m_{AS}^{(sat)} = 5.790$ mol/kg, while measurements are most often not available for the solubility limit of AS in
184 aqueous inorganic-organic systems. However, crystalline AS in equilibrium with an aqueous mixture
185 demonstrates a specific molal ion activity product (IAP) in that solution at a given temperature and
186 atmospheric pressure. For example, in the case of a ternary liquid mixture of levoglucosan + AS + water
187 in solid-liquid equilibrium (SLE) with a crystalline AS phase at a certain temperature T, a constant molal
188 ion activity product $IAP_{AS} = IAP_{AS}^{(sat)}(T)$ is established (necessary SLE condition). In this case the liquid
189 mixture is a so-called saturated solution with respect to AS. While the molar amount of AS in a saturated
190 solution depends on the other mixture constituents, the value of $IAP_{AS}^{(sat)}(T)$ is a function of temperature
191 only, since it is derived from the fixed chemical composition and associated chemical potential of the
192 crystalline phase. A reference value for $IAP_{AS}^{(sat)}(T)$ can therefore be calculated with the AIOMFAC
193 model from an experimentally determined solubility limit of AS in a known mixtures, such as the
194 molality of AS at the point of saturation in the binary aqueous system (water + AS). The RH at which
195 full dissolution of a solid phase upon humidification is just reached, the DRH, is directly related to the
196 conditions at which a saturated solution becomes subsaturated upon addition of water. Here the degree
197 of saturation with AS can be determined unambiguously by the computed value of IAP_{AS} as a function
198 of mixture composition and temperature. Making use of these thermodynamic relationships, the
199 AIOMFAC-based equilibrium model is used to calculate the DRH and ERH of AS in the multicomponent
200 system, as outlined below. Detailed information on the modeling of solid-liquid equilibria and the IAP-
201 based prediction of ERH is given in Zuend et al. (2011) and Hodas et al. (2016). Briefly, the ERH is

202 determined based on the following equations:

$$203 \quad \text{IAP}_{\text{AS}} = \left[a_{\text{NH}_4^+}^{(m)} \right]^2 \left[a_{\text{SO}_4^{2-}}^{(m)} \right]^1 \quad (1)$$

$$204 \quad \text{IAP}_{\text{AS}}^{[\text{crit}]} = c_{\text{AS}} \times \text{IAP}_{\text{AS}}^{(\text{sat})} \quad (2)$$

205 Here $a_{\text{NH}_4^+}^{(m)}$ and $a_{\text{SO}_4^{2-}}^{(m)}$ are the molal activities of the ammonium and sulfate ions in solution (Zuend et
206 al., 2010). Molality basis is indicated by superscript “(m)” (which is not a mathematical exponent).
207 $\text{IAP}_{\text{AS}}^{(\text{sat})}$ denotes the molal ion activity product of AS at salt saturation computed by the thermodynamic
208 equilibrium model for any aqueous AS system at a certain temperature (here 298.15 K). The calculated
209 molal IAP at saturation of the corresponding binary salt solution is taken as the (known) reference value.
210 The RH at which this $\text{IAP}_{\text{AS}}^{[\text{sat}]}$ value is just reached in certain bulk solution at equilibrium with its
211 environment (in contrast to $\text{IAP}_{\text{AS}} < \text{IAP}_{\text{AS}}^{(\text{sat})}$ at higher RH), is the (bulk) DRH of AS. Similarly, the ERH
212 is determined at the point of crystallization by a critical IAP value denoted as $\text{IAP}_{\text{AS}}^{[\text{crit}]}$ (Hodas et al.,
213 2016), the value of $\text{IAP}_{\text{AS}}^{[\text{crit}]} > \text{IAP}_{\text{AS}}^{[\text{sat}]}$ expresses the need for reaching a critical IAP threshold (critical
214 level of AS super-saturation) for highly likely nucleation-and-growth of a new crystalline AS phase. The
215 multiplication factor c_{AS} is used as a constant coefficient relating the IAP at AS saturation to the one
216 expected at the point of crystallization in aqueous mixed particles. From the comparison of laboratory
217 measurement of ERH for aqueous AS solution to the AIOMFAC-predicted IAP_{AS} at that RH, the value
218 of $c_{\text{AS}} \approx 30$ was determined; this value is in particular applicable to submicron-sized AS droplets (Zardini
219 et al., 2008; Ciobannu et al., 2010).

220 An analogous approach is used for the ERH predictions with the E-AIM model, however, since E-AIM
221 provides activity coefficients and activities on mole fraction basis, denoted here by superscript “(x)”
222 (rather than molality basis), the value of $c_{\text{AS}}^{(x)}$ need to be determined separately for that model.
223 Expressing Eq. (1) by mole-fraction-based activities of NH_4^+ and SO_4^{2-} and comparison to the
224 $\text{IAP}_{\text{AS}}^{(\text{sat},x)}$ and $\text{IAP}_{\text{AS}}^{(\text{crit},x)}$ computed by E-AIM for AS at the experimental solubility limit and ERH in
225 aqueous AS solutions, a value of $c_{\text{AS}}^{(x)} \approx 40$ was determined for the calculation with E-AIM.

226 As discussed by Lei et al. (2014), predicting of hygroscopic growth factors with E-AIM includes a
227 sophisticated composition-dependent solution density model, which considers the non-ideality effects on
228 apparent molar volumes used for the calculation of the solution density in mixed organic-inorganic

229 systems (Clegg and Wexler, 2011a, b). The AIOMFAC-based model applies a simpler solution density
 230 treatment by assuming that the partial molar volumes of solution species are independent of non-ideal
 231 interactions, i.e. the mixed solution density is calculated based on linear additivity of pure component
 232 solid or liquid volume contributions to obtain the HGF at a given RH. Differences in the density models
 233 are expected to lead to relatively small differences, typically on the order of the HTDMA measurement
 234 error or less (e.g. Fig. 2a), in the application to HGF predictions, as demonstrated by Lei et al. (2014) for
 235 the case of diameter vs. mass-based HGF of AS droplets. Both models include sophisticated sets of
 236 equations to compute activity coefficients of all solution components in a thermodynamically consistent
 237 manner.

238 2.4 κ -Köhler theory and computation of the hygroscopicity parameter κ

239 The hygroscopicity parameter, κ , is commonly used to characterize the relative hygroscopicities of
 240 individual aerosol particles, known mixtures or complicated atmospheric aerosols (Petters and
 241 Kreidenweis, 2007), and to model the composition-dependence of the solution water activity. The
 242 saturation ratio, S , in the traditional Köhler equation (Eq. 3), over an aqueous droplet is calculated from

$$243 \quad S = a_w \left(\frac{4\sigma_s M_w}{RT \rho_w D_{wet}} \right) \quad (3)$$

244 Where a_w is the mole-fraction-based water activity in solution, M_w and ρ_w are the molar mass of water
 245 and the density of pure water in the liquid state at temperature T , respectively. D_{wet} , the “wet” particle
 246 diameter at a given RH, is defined by $D_{wet} = HGF \times D_0$. D_0 denotes the diameter at dry conditions at
 247 RH below 5 %. The solution surface tension is denoted by σ_s . In the “ κ -Köhler theory”, the bulk solution
 248 water activity is described by a single parameter κ , with the hygroscopic parameter of the overall mixture
 249 related to Eq. (3) by

$$250 \quad \kappa_{HGF} = 1 - HGF^3 + \frac{HGF^3 - 1}{S} \exp \left[\frac{4\sigma M_w}{RT \rho_w D_{wet}} \right] \quad (4)$$

251 This expression describes effective values of κ_{HGF} as a function of droplet diameter and HGF at a
 252 certain saturation ratio. In turn, known (measured) solution κ_{HGF} values or component-specific κ_i
 253 values can be used to parameterize or predict the HGF curve of a mixture (Petters and Kreidenweis,
 254 2007).

255 2.5 GF data fit

256 As described by Dick et al. (2001), the relationship between measured hygroscopic growth factors and
257 water activity can alternatively be parameterized by the following expression:

$$258 \quad HGF = \left[1 + (c_1 + c_2 \times a_w + c_3 \times a_w^2) \frac{a_w}{1-a_w} \right]^{\frac{1}{3}} \quad (5)$$

259 By substitution of Eq. (3) for a_w in Eq. (5) and a fit to the measured HGF the three adjustable coefficients
260 c_1 , c_2 , c_3 of Eq. (5) were determined. The coefficient values are given in Table 3 for the different
261 organic compounds considered.

262 2.6 GF prediction by ZSR

263 The Zdanovskii-Stokes-Robinson mixing rule is widely used to approximate the water uptake of mixed
264 systems by assuming additivity of the water uptake of each individual component in the mixed particles
265 at a given RH (e.g., Malm and Kreidenweis, 1997). HGF_{mix} is based on the HGF_j of pure components j
266 and their corresponding volume fraction, ε_j in the mixed particles.

$$267 \quad HGF_{mix} = \left[\sum_j \varepsilon_j (HGF_j)^3 \right]^{\frac{1}{3}} \quad (6)$$

268

269 3. Results and discussion

270 3.1 GF of single compounds systems

271 Figure 2a shows the measured diameter growth factors of AS particles as a function of RH for both
272 humidification and dehumidification conditions. The measured ERH of 100 nm AS particles is
273 approximately 35 % RH at 298.15 K. The models predicted GF and predicted solid-liquid phase transition
274 of AS are in relatively good agreement with the experimental data and, in particular, the efflorescence
275 (crystallization) of AS is captured by the AIOMFAC and E-AIM models. The good model-measurement
276 agreement for the ERH is of course expected, since the aqueous AS system serves as the reference system
277 for determining the value pairs of $IAP_{AS}^{(sat)}$ and c_{AS} on molality and mole fraction basis for use with
278 AIOMFAC and E-AIM, respectively (section 2.3). An ERH of 31 % to 40 % RH was reported by other
279 groups for a range of particle sizes and experimental techniques (Zardini et al., 2008; Ciobanu et al.,

280 2010). There are several factors that contributed to the variability of reported ERH values, such as
281 particles size, temperature, solution impurities and the stochastic nature of the homogeneous or
282 heterogeneous nucleation of a crystalline phase near ERH (Ciobanu et al., 2010).

283 In Fig. 2b, upon dehydration, no efflorescence of the levoglucosan aerosol particles is observed even
284 at RH below 10 %. The agreement of the HGF between the hydration and dehydration processes
285 demonstrates that these particles equilibrate with the surrounding water vapor under these moisture
286 conditions. For example, the measured diameter growth factors of levoglucosan particles at 80, 60, and
287 30 % RH are 1.19, 1.09, and 1.03, respectively, which are similar to results obtained for the hydration
288 process of such particles. Levoglucosan has a DRH of ~80 % to 83 % (for a bulk system) at 293 to 298 K
289 (Mochida and Kawamura, 2004; Zamora et al., 2011). The similarity of diameter growth factors both
290 under hydration and dehydration conditions even below the DRH of levoglucosan is explained by the
291 lack of crystallization of levoglucosan upon drying to low RH and the presence of a metastable
292 supersaturated aqueous levoglucosan solution in both the hydration and dehydration modes for
293 experiments initiated with liquid solution droplets (Mochida and Kawamura, 2004; Chan et al., 2005;
294 Svenningsson et al., 2006). A possible reason for a persistent metastable supersaturated solution states is
295 that levoglucosan particles remain liquid (possibly a viscous liquid state) upon drying to below 5 % RH,
296 which was also observed previously with a reported ERH < 4% RH (Mochida and Kawamura, 2004;
297 Chan et al., 2005). Also, the measured diameter growth factors of levoglucosan particles are in good
298 agreement with these estimated from the standard UNIFAC model within the E-AIM model and the
299 AIOMFAC model, within experimental uncertainty. The UNIFAC models within E-AIM and AIOMFAC
300 are based on the original model expressions by Fredenslund et al. (1975) and both include the extensive
301 parameter set by Hansen et al. (1991) as well as revised parameters for certain group interactions of water
302 with carboxyl and hydroxyl groups by Peng et al. (2001). Of relevance for levoglucosan and other sugar-
303 like compounds, the AIOMFAC model also contains certain revised group parameters for hydroxyl
304 groups and special alkyl groups for their interactions with water, introduced by Marcolli and Peter (2005)
305 for polyols, as further detailed in Zuend et al. (2011). However, the molecular structure of levoglucosan
306 with several polar functional groups in close vicinity may account for a small deviation between models
307 and measured *HGFs* at RH below 70 %, because intramolecular interactions are not fully considered by
308 these models.

309 The measured diameter growth factors of 4-hydroxybenzoic acid particles shown in Fig. 2c
310 demonstrate untypical increase in diameter of 4-hydroxybenzoic acid particles during dehumidification
311 from 90 to 10 % RH, which is consistent with previous diameter growth factor for a few solid particles
312 (Mochida and Kawamura, 2004). The organic particles measured are likely always in the effloresced, i.e.
313 crystalline state apparently even at high RH. The apparent increase in diameter during dehumidification
314 may be explained by particle shape restructuring, since the (poly)-crystalline particles are likely non-
315 spherical at dry conditions, but may become more sphere-like in shape when exposed to higher RH
316 (Mikhailov et al., 2004). Also, no ERH of 4-hydroxybenzoic acid in the dehydration mode was observed
317 during the experiments; the likely reason is that the highest RH reached in the humidifier was
318 approximately 98 %, which may be below the ERH of 4-hydroxybenzoic acid, reported as above 98 %
319 RH in another study (Mochida and Kawamura, 2004). As discussed previously by Lei et al. (2014), our
320 HTDMA experiments are carried out such that RH = 98 % is reached initially before dehumidification
321 to a series of relative humidities at set point RH2 (90 % – 5 % RH), the crystallization of the organic,
322 however, could occur at above 90 % RH. In addition, deviations between measurements and model
323 prediction are obvious in Fig. 2c. The observations surpass by far the expected error in model
324 performance, which is typically less than 0.05 in HGF units for RH < 85 %, as indicated also by an
325 intercomparison of the AIOMFAC and E-AIM predictions in Fig. 2c and much improved model-
326 measurement agreement for the case of mixed 4-hydroxybenzoic acid + AS particles shown in Fig. 4
327 (discussed in Section 3. 2. 2). However, note that the validity of the shown model predictions in Fig. 2c
328 depends on whether the assumption of a liquid solution droplet is plausible. Therefore, it is no surprise
329 that the model-predicted curves deviate from the experimental hygroscopic behavior of 4-
330 hydroxybenzoic acid particles. Morphology effects, such as the restructuring of non-spherical
331 polycrystalline particles over a certain RH range or liquid-liquid phase-separated particles of non-
332 spherical shapes, have been discussed by several groups (Sjogren et al., 2007; Reid et al., 2011; Lei et
333 al., 2014). In the case of hygroscopic growth and deliquescence under hydration conditions for 4-
334 hydroxybenzoic acid particles and mixtures of 4-hydroxybenzoic acid with ammonium sulfate. An offset
335 between measurement and model predictions was observed both in the RH range below the deliquescence
336 of the particles and above it, i.e. above 80 % RH, (Lei et al., 2014). It is suggested that deviations are
337 primarily caused by a change in solid-state particle morphology during hydration, leading to a
338 restructuring of the polycrystalline particle shape towards more compact, near-spherical shape as the RH

339 approaches the particle deliquescence point. This would explain rather uncommon HGF values of less
340 than 1.0 at elevated RH also shown in Fig. 2c. Similar behavior was found for experimental growth
341 factors of mixtures containing adipic acid and AS and systematic deviations between the associated ZSR
342 predictions and observations by Sjogren et al. (2007). Thus, while experimental data hint to the possible
343 influence of non-spherical particles and their humidity-induced restructuring as a source of uncertainty,
344 model predictions of HGF, such as those with the AIOMFAC model, assume by default a spherical
345 particle shape even for solid phases and/or in cases where LLPS is present.

346 The measured HGF curves of humic acid aerosol particles during dehumidification and humidification
347 measurements do not agree very well within experimental uncertainty, in particular above 70 % RH. For
348 instance, the growth factor of humic acid aerosol particles at 80 % RH is 1.2 according to the
349 dehumidification measurement, which is higher than hygroscopic growth factor of humic acid particles
350 in the humidification mode at the same RH. Humic acid aerosol particles shrink continuously due to loss
351 of water content in the range from 90 % to 10 % RH. For example, a stepwise change in the water
352 absorption and desorption behavior within different RH range was observed in the case of Nordic Aquatic
353 Fulvic Acid (NAFA) and Suwannee River Fulvic Acid (SRFA) by Chan and Chan (2005). These
354 hygroscopic behaviors suggest that humic acid particles and structurally similar compounds remain some
355 water down to the low RH levels achieved in the instruments (imperfect drying during particle residence
356 in the instrument). In addition, the experimental growth factor of humic acid aerosol particles during
357 dehumidification can be represented well by fitting Eq. (5) to the measurements. The determined fit
358 parameters are listed in Table 3. The humic acid sample used (Aldrich, 99%) are a mixture of different
359 poly-carboxylic acids of undefined chemical structure. However, specific information on the chemical
360 structure and mixture composition is necessary for corresponding model predictions with AIOMFAC and
361 E-AIM. Therefore, no such model calculations are shown in Fig. 2d.

362 **3.2 GF of mixtures of organic surrogate compounds + ammonium sulfate**

363 Biomass burning aerosol particles are likely mixtures of a diversity of inorganic constituents and organic
364 compounds in the atmosphere. For example, particles may consist of a combination of ammonium sulfate
365 mixed with low- and semi-volatile organics from biomass burning emissions (Lee et al., 2003; Zhang et
366 al., 2007; Pratt and Prather, 2010). Different water solubilities, and hygroscopic behavior of distinct

367 organic compounds may affect the hygroscopic growth factors of mixtures of partially or fully dissolved
368 inorganic and organic components. For example, Bodsworth et al. (2010) studied the effect of different
369 mass fractions of citric acid on the efflorescence properties of mixed citric acid-ammonium sulfate
370 particles at lower temperature and concluded that adding citric acid decreases the ERH of ammonium
371 sulfate in the mixed aerosol particles. These hygroscopic behaviors of mixed aerosol particles, including
372 phase transition in the range from moderate to low RH, are the focus of attention in this study.

373 **3.2.1 Mixed system: levoglucosan + ammonium sulfate**

374 Figure 3 shows measured growth factors of mixed aerosol particles containing levoglucosan +
375 ammonium sulfate with different dry state organic-to-inorganic mass ratios (1:3, 1:1, 3:1) in the RH range
376 from 90 % to 10 %. There is a reduction in the diameter growth factor of aerosol particles containing
377 levoglucosan and AS with increasing levoglucosan mass fraction, as expected from a ZSR-like additivity
378 concept of hygroscopicity. When the concentration of levoglucosan is low (25 wt %), a clear
379 efflorescence signature of AS found, within the ERH shifting to a higher RH (40 % - 45 %) in comparison
380 to the ERH of pure AS occurring at 33 %-35 % RH (Fig.3a). A similar phenomenon has been found for
381 the certain mixtures of NaCl and Nordic Aquatic Fulvic Acid (NAFA), in which the crystallization of
382 NaCl shifted to higher RH by mixing with NAFA at a mass ratio of 1:1 (Chan and Chan. 2003). With
383 increasing mass fraction of levoglucosan (i.e., 50 wt % and 75 wt %), the mixtures release water gradually
384 and no crystallization of AS was observed. Although a small step in the growth factor curve might have
385 occurred (indicative of the crystallization of AS), it cannot be detected with sufficient certainty by our
386 measurement setup. The rather high viscosity of solutions containing levoglucosan is expected to
387 increase considerably toward RH (Marshall et al., 2016). This increase in viscosity might impede the
388 crystallization of AS in the mixed systems on the time scale of the experiment. Mass transfer limitation
389 effects on the deliquescence or efflorescence process of crystalline organic particles and the water uptake
390 or evaporation have been investigated in several experimental studies (Peng et al., 2001; Choi and Chan,
391 2002; Chan and Chan, 2005; Sjogren et al., 2007; Zardini et al., 2008; Ciobanu et al., 2010; Smith et al.,
392 2012; Mikhailov et al., 2013; Hodas et al., 2015). Mass transfer limitations may impact the outcome of
393 experiments significantly if the characteristic time scales for equilibration is similar to or larger than the
394 residence time of particles in the experimental setup. In this study, the total residence time of the aerosol
395 sample during the equilibration phase before entering the DMA2 is about 8 s. In order to improve the

396 probability that the particles reach equilibrium with the target RH during this residence time, the
397 monodisperse aerosol selected by DMA1 is first humidified to 98 % RH. The aerosol particles are then
398 exposed to a lower target RH by a two-step process using double Nafion tubes. Kerminen (1997)
399 estimated the necessary residence time for achievement of water equilibrium of aqueous droplets to be
400 between 8×10^{-6} s and 0.1 s for 100 nm and 500 nm particles, respectively. Therefore, the typical
401 residence time of a few seconds in the humidification or dehumidification section in a HTDMA
402 measurement is assumed to be sufficient for most equilibrium hygroscopicity measurements (Brooks et
403 al., 2004; Mikhailov et al., 2004). Moreover, our HGF results for the three pure organic components are
404 in good agreement with respective data by Mochida and Kawamura, (2004), Brooks et al., (2004) and
405 Chan and Chan (2005) conducted with different techniques and/or residence times. However, there are
406 cases where water equilibration could be impeded substantially in the presence of highly viscous or
407 glassy particles at low RH, e.g. for ternary sucrose + NaCl + water particles of $> 6 \mu\text{m}$ in diameter studied
408 by Bones et al. (2012), who report an equilibration time scale > 1000 s for such particles. Note that, aside
409 from viscosity, there is an important size-dependence of the particles on the equilibration time scale (e.g.
410 Koop et al. 2011). For aqueous 100 nm particles used in HTDMA experiments at room temperature,
411 Bones et al. (2012) indicate that the equilibration time scale for water is likely only of concern for RH $<$
412 10 % in such an instrument. We therefore conclude that the residence time of 8 s is very likely sufficient
413 to allow for equilibrium HGF measurements in dehydration mode, at least down to 10 % RH (when
414 starting with aqueous solution droplets).

415 Mass transfer effects in hygroscopicity measurements of aerosol particles during hydration conditions
416 have been encountered previously, particularly when a solid-liquid phase transition (deliquescence) is
417 involved (Peng et al., 2001; Chan and Chan, 2005; Sjogren et al., 2006). For example, Peng et al. (2001)
418 observed in electrodynamic balance (EDB) experiments under conditions of very slow humidification
419 that glutaric acid aerosol particles showed a deliquescence phase transition in the RH range from 83 to
420 85 % over the course of several hours. This is a much longer time span than that of ~ 40 min for the
421 deliquescence of other super-micron sized dicarboxylic acid particles (e.g., malonic acid) in EDB
422 experiments. This observation indicates that the solid-liquid phase transition of glutaric acid particles
423 may likely be mass transfer limited during the hydration process. In this context, it is possible that the
424 deliquescence of initially solid, pure 4-hydroxybenzoic acid particles at RH > 97 % is further impeded

425 by slow dissolution, which could have led to the absence of deliquesced particles (Fig. 2c) on
426 experimental time scale.

427 In addition, the measured diameter growth factors of mixtures of levoglucosan and AS are compared
428 to calculations of hygroscopic growth by the E-AIM and AIOMFAC models. The E-AIM prediction is
429 in relatively good agreement with results from the HTDMA measurement but typically overestimates the
430 water content of particles consisting of organic-AS mixtures at the RH range close to the ERH of AS.
431 The liquid-solid phase transition of ammonium sulfate in the mixed particles is considered in the E-AIM
432 assumptions as described in Section 2.3. There is a more distinct shift of ERH of AS with higher mass
433 fractions of levoglucosan. In the case of the AIOMFAC and E-AIM model predictions, it is assumed that
434 the diameter growth factor contribution from AS is zero below the predicted ERH, i.e. there the growth
435 factor deviation from 1.0 is solely due to the organic water uptake. The model prediction shows a slight
436 deviation from the measurements, which may be in part due to (i) model uncertainty in the correct
437 description of the hygroscopicity of levoglucosan, (ii) due to incomplete representation of AS +
438 levoglucosan interactions in aqueous solutions and (iii) in part due to measurement error. Also, in the
439 case of mixtures consisting of AS and levoglucosan with organic-to-inorganic dry mass ratio of 3:1 (75
440 wt % levoglucosan of dry particle composition), the underestimation of the growth factor by the
441 AIOMFAC model at $RH < 35\%$ in comparison to the measurements is explained in part by the model
442 prediction of AS efflorescence (which seems to be absent in the measurements). However, with
443 decreasing AS mass fraction, the hygroscopic behavior of levoglucosan dominates the diameter growth
444 factors of the mixtures, in relative agreement with the AIOMFAC-modeled “dehydration branch”
445 prediction. Minor differences in the AIOMFAC prediction vs. -measurement for diameter growth factors
446 of mixed levoglucosan and AS in the RH range of 35 - 25 % here might be attributed to mixture viscosity
447 effects at the higher levoglucosan contents, which may suppress the efflorescence of AS in the mixed
448 systems on experimental timescale or it could simply be due to sufficient miscibility of dissolved AS in
449 the aqueous levoglucosan solution (beyond that predicted by the model), such that a small step-change
450 due to AS efflorescence could be beyond the experimental detection range. As a result, accounting for
451 the effect of the organic components on the diameter growth factors of mixtures within aerosol particles
452 is crucial to model accurately the equilibrium hygroscopic behavior.

453 **3.2.2 Mixed system: 4-hydroxybenzoic acid + ammonium sulfate**

454 Mixtures of 4-hydroxybenzoic acid + AS with different organic mass fraction (25, 50, 75 wt %) exhibit
455 a gradual water desorption before the AS fraction of the particle effloresces at a certain RH. With
456 increasing 4-hydroxybenzoic acid mass fraction, no discontinuity step at the corresponding ERH in the
457 dehydration curve of mixtures is observed. This suggests the presence of 4-hydroxybenzoic acid in the
458 liquid state retards or offsets the efflorescence of AS in the mixtures. An interesting, yet contrasting
459 phenomenon was observed for the hydration process of aerosol mixtures containing 4-hydroxybenzoic
460 acid and AS by Lei et al. (2014). For the case of these mixtures during moistening, the deliquescence of
461 ammonium sulfate in the mixed particles remains unaffected, within experimental resolution, by the
462 presence of 4-hydroxybenzoic acid (Lei et al., 2014). Similar behavior has been observed for particles
463 containing certain organic acids of limited water-solubility mixed ammonium sulfate (Choi and Chan,
464 2002; Chan and Chan, 2003). For example, mixtures for succinic acid + ammonium sulfate showed no
465 substantial influence on the deliquescence RH of ammonium sulfate in the hydration process (Choi and
466 Chan, 2002). However, a clear RH shift of the deliquescence phase transition of ammonium sulfate or
467 sodium chloride was determined for mixed particles containing organic acids of higher water-solubility
468 and O: C ratio, such as citric acid and malonic acid (e.g. Choi and Chan, 2002). The DRH and ERH of
469 pure organics and AS in the mixed organic-AS particles are summarized in Table 4, the measurements
470 indicate that 4-hydroxybenzoic acid has a significant effect on the efflorescence of AS when present in
471 sufficient amount. Also, there is a clear reduction in the diameter growth factors prior to crystallization
472 for mixtures with increasing 4-hydroxybenzoic acid mass fraction.

473 The measurements of mixtures consisting of 4-hydroxybenzoic acid and AS are compared with model
474 predictions based on different assumptions about the phase state of the organic component, since the
475 deviation from measurements might partly be explained by a transition in the physical state of the organic
476 component. The E-AIM model prediction is referring to a system where the mixtures of 4-
477 hydroxybenzoic acid is assumed to be in the liquid state at all RH levels, which the efflorescence of AS
478 is considered. Neglecting the potential efflorescence of the organic component in the dehydration branch
479 makes a systematic offset more obvious prior to the efflorescence of AS. A good E-AIM model-
480 measurement agreement occurs below the predicted ERH of AS for mixed particles. The overestimation
481 of HGFs before the efflorescence of AS is explained by the AIOMFAC model prediction with distinct
482 assumptions about the organic phase state. A possible reason for the departure of model-measurement

483 agreement at $RH < 80\%$ is that there are two liquid-to-solid phase transitions, occurring in the mixed
484 particles: a gradual one for the organic component and a step-like one for AS at lower RH. This
485 phenomenon is shown in the grid square range in Fig. 4 and supported by comparison of the measured
486 HGF data with AIOMFAC-based predictions for two assumptions about the organic phase state,
487 especially in the case of mixtures with 50 and 75 wt-% organic. We acknowledge that the model
488 predictions of the HGF curves for the two organic phase state assumptions differ within experimental
489 error for the case shown in Fig. 4a, indicating that alternative explanations, such as model/measurement
490 uncertainty in the absence of a liquid-solid phase transition could explain the observations. In the Fig.
491 4b, good agreement between measurements and the AIOMFAC model prediction with liquid organic
492 assumption is found for $RH > 65\%$, while for $RH \leq 60\%$ the experimental data agree very well with the
493 dashed red model curve for the case with consideration of a solid organic component. It suggests that
494 crystallization followed by gradually increasing partitioning of organic from the solution to the solid
495 organic phase occurs in the range from 70 % to 60 % RH under conditions of dehumidification. Similarly,
496 a liquid-to-solid phase transition occurs for the organic: AS mass ratio of 3:1 cases in the range from 80 %
497 to 50 % RH. Meanwhile, AS remains dissolved in a supersaturated aqueous solution phase. Moreover,
498 the AIOMFAC-based equilibrium model predicts a liquid-liquid phase separation (LLPS) to occur at RH
499 below $\sim 90\%$ for the calculation cases with the assumption of the organic in the liquid state (for all three
500 organic mass fractions in Fig. 4). This prediction leads to a liquid phase enriched in 4-hydroxybenzoic
501 acid with some water and AS dissolved and a coexisting liquid phase enriched in AS and water. The onset
502 of the LLPS during dehumidification leads to the kink in the red model curve near 90 % RH, since the
503 slope of the HGF curve with RH changes in a non-smooth manner at the point of the LLPS phase
504 transition. This change in slope is not noticeable from the experimental data alone, but the model-
505 measurement comparison for the range above 80 % RH shows very good agreement. The two liquid
506 phases will likely remain separated until nucleation of a crystalline 4-hydroxybenzoic acid phase occurs
507 followed by gradual partitioning of the organic acid to the solid phase with decreasing RH (to $\sim 50\%$
508 RH), at which point only a single liquid phase (an aqueous AS phase with a tiny amount of dissolved
509 HA) will remain until efflorescence of AS occurs. Above $\sim 90\%$ RH, a single, homogeneous liquid phase
510 is predicted to exist. Interestingly, this AIOMFAC model-measurement comparison (Fig. 4, especially
511 panels b and c) provides reasonable evidence that 4-hydroxybenzoic acid remains dissolved and therefore
512 in a liquid phase state at high RH in the mixed particles upon dehumidification (it is present in both liquid

513 phases below 90 % RH, but highly enriched in the AS-poor phase). In contrast, in the case of pure 4-
514 hydroxybenzoic acid aerosol particles, particles exposed to initial RH of ≥ 90 % remain in the solid state
515 (or crystallize at RH > 90 %) in the dehydration mode (Fig. 2c). What factors contribute to keeping the
516 organic in the liquid solution? It is possible that the aerosols generated with those mixed solutions were
517 allowing the 4-hydroxybenzoic acid to fully dissolve as the AS provides substantial particle phase water
518 content (within short time) into which the organic can be dissolved and may then further contribute to
519 water uptake associated with the organic's hygroscopicity (unlike in the case of the pure 4-
520 hydroxybenzoic acid particles). The 4-hydroxybenzoic acid remains dissolved in the mixture, possibly
521 supersaturated with respect to the crystalline organic state (similarly to how AS stays supersaturated at
522 RH below the DRH during drying). We consider this a reasonable explanation for the observed HGF data
523 from the HTDMA in comparison to the different AIOMFAC-based curves.

524 **3.2.3 Mixed system: humic acid + ammonium sulfate**

525 Figure 5 shows that the experimental diameter growth factors of mixtures consisting of humic acid (HA)
526 and AS with dry mass ratios of 1:3, 1:1 or 3:1 decreases with increasing mass fraction of HA at RH $>$
527 35 %. For example, at 35 % RH the measured HGF are 1.1, 1.05, 1.05 for the particles consisting of 25
528 wt %, 50 wt % and 75 wt % humic acid. In comparison, the diameter growth factor of pure supersaturated
529 AS particles is ~ 1.13 just prior to efflorescence of AS. Humic acid, unlike levoglucosan and 4-
530 hydroxybenzoic acid aerosol particles, has no noticeable effect on the efflorescence point of AS in the
531 mixed aerosol particles. Results of the ZSR model agrees well with measured hygroscopic growth for
532 mixtures within the experimental error. The ZSR curves shown in Fig. 5 are based on the RH-dependent
533 fitted hygroscopic growth factors of humic acid with Eq. (5) and the AIOMFAC predicted diameter
534 growth factors of AS in the dehydration mode. The success of the ZSR mixing rule for this system
535 suggests that interactions of organic molecules with ammonium sulfate ions in aqueous solution will only
536 marginally affect the hygroscopic growth factors of the mixtures containing humic acid and AS. Due to
537 the lack of detailed information about the actual chemical structures of humic acid samples used, it was
538 not possible to perform E-AIM and AIOMFAC model predictions for comparison with the measurement.

539 **3.3 Mixtures of biomass burning organic surrogate components with ammonium sulfate**

540 According to Decesari et al, (2006), sampling of aerosol particles, including the WSOC fraction, was

541 conducted from September 9 to November 14, 2002 in their field study, the sampling time was subdivided
542 into different periods. Despite of significant changes in the chemical composition of tracer compounds
543 from the dry to the wet period, the functional groups and general chemical classes of WSOC changed
544 only to a small extent in the Amazon basin near Rondônia, Brazil. Model compounds represent semi-
545 quantitatively (presence/abundance of functional groups) and the chemical structure of WSOC can be
546 used as surrogates in microphysical models involving organic aerosol particles over tropical areas
547 affected by biomass burning scenarios (Andreae et al., 2002; Artaxo et al., 2002; Rissler et al., 2006;
548 Decesari et al., 2006). Here, we focus on experimental observations and model calculations for relatively
549 simple mixtures of inorganic-organic surrogate components reflecting mixtures of aerosol components
550 found during different seasons during biomass burning events. However, we are fully aware of that fact
551 that actual biomass burning aerosols are typically much more complex in terms of particle chemical
552 composition. Aerosol particle properties from biomass burning events depend on the types of sources,
553 external/internal population mixing state, water-solubilities, and phase state of the diversity of organic
554 compounds and their mixing with inorganic constituents during different time periods in the field (e.g.
555 Decesari et al., 2006).

556 **3.3.1 Mixtures system: mix-bio-dry and mix-bio-wet aerosol particles**

557 Figure 6a shows the observed small differences in the hygroscopicity parameter κ for mixtures of organic
558 surrogate components and ammonium sulfate representing biomass burning particles during the dry and
559 wet periods in the Amazon, respectively. Hygroscopicity parameter values for bio-mix-dry aerosol
560 particles were determined to be between 0.16 and 0.18 with decreasing RH in the range from 90 % to
561 40 % RH. The κ value representing the wet period in the Amazon is shown in Fig. 6b, derived from
562 laboratory HTDMA measurements in the range from 90 % to 40 % RH. A similar trend of an increase in
563 κ with a decrease in RH has also been observed by Cheung et al. (2015). Their observation is based on
564 ambient particle measurement with a HTDMA in Hong Kong, therefore probing particles of more
565 complex compositions in the field campaign. The variability of the hygroscopicity parameter in sub-
566 saturated conditions reveals some limitations of a single-parameter hygroscopicity model for applications
567 over a wide range of RH. At low, intermediate and high RH levels, differing degrees of solution non-
568 ideality, potential for liquid-liquid phase separation, water-solubility limitations of organics in ambient
569 organic-inorganic particles, and assumptions about constant/variable surface tension may all play a role

570 (Mikhailov et al., 2009; Wex et al., 2009, Rastak et al., 2017; Ovadnevaite et al. 2017; Wang et al., 2017).
571 In the case of κ of organic surrogates mixed with ammonium sulfate, the relevant κ value range is ~ 0.12
572 to 0.15 obtained from 90 % to 40 % RH. The measured κ values of the mixtures are compared to field
573 data of HTDMA and CCN measurements conducted at a remote rainforest site in the central Amazon
574 during the dry and wet seasons (Whitehead et al., 2016; Pöhlker et al., 2016), which are consistent with
575 κ obtained at similar field sites (within the uncertainty of experiments). The likely reason for a relatively
576 good agreement between the hygroscopicity of the laboratory mixtures and the field data is that the
577 organic mass fractions of the mix-bio-dry and mix-bio-wet mixtures are chosen in our laboratory
578 experiments to be similar to those of the latest field data from Amazon. For example, Pöhlker et al. (2016)
579 obtained the effective hygroscopicity parameters κ between 0.3 ± 0.01 and 0.15 ± 0.01 based on the
580 organic mass fraction range from 0.65 to 0.97 in the dry season by aerosol chemical speciation monitor
581 (ACSM) and CCN measurements. The predicted κ values of the mixtures at various RH levels shown in
582 Fig. 6 (black curves) are obtained by application of Eq. (4) with use of the RH-dependent fitted HGFs of
583 the organic surrogates (Eq. 5), the predicted growth factor of AS by the AIOMFAC model (for the
584 humidification case) and the volume fraction based mixing rule for a mixture's HGF (Eq. 6). For these
585 calculations, a solution surface tension of 0.072 J m^{-2} was assumed. These predictions agree relatively
586 well with the experimental κ_{dry} and κ_{wet} values obtained from the HTDMA over a wide range in RH
587 referring to dehumidification conditions (no solid AS). Furthermore, the combined approach of Eqs. (4-
588 6) allows for a prediction of the change in κ at high RH towards water vapor super-saturation. A small
589 difference in κ between sub- and super-saturated conditions is observed for our mixed systems when
590 comparing the HTDMA data and predictions at 90 % RH with the predictions near 100 % RH and the κ
591 values from the CNN field measurements. The difference is more pronounced for the wet season case.
592 Rastak et al. (2017) observed a marked difference in apparent hygroscopicity and related mixture κ of
593 the organic aerosols (AS-free) occurring in the case of monoterpene-derived secondary organic aerosol
594 (SOA) for sub- vs. super-saturated conditions. A smaller difference was reported for the isoprene-derived
595 SOA (Pajunoja et al., 2015; Rastak et al., 2017), more like the difference observed here for the mixtures
596 containing AS (and therefore having overall higher κ values than typical salt-free organic aerosols).
597 Rastak et al. (2017) attribute the distinct difference in κ_{SOA} of the monoterpene SOA to the limited mutual
598 solubility of certain SOA components in water, because a single liquid organic-phase of monoterpene
599 oxidation products is present at RH below 95 %, but over a RH range above 95 %, liquid-liquid phase

600 separation is observed by optical microscopy as well as predicted by the AIOMFAC-based equilibrium
601 model. In the mix-bio-wet and mix-bio-dry cases shown in Fig. 6, the likely reason for the change in
602 characteristic mixture hygroscopicity is not necessarily due to a liquid-liquid phase separation at high
603 RH. For example, the κ parameter obtained from field data is $\sim 0.15 \pm 0.06$ at 90 % RH, while its value
604 reaches $\sim 0.18 \pm 0.04$ at RH > 100 % (just prior to CCN activation). A likely reason for the difference is
605 that hygroscopic particles, especially those containing sparingly soluble organics like 4-hydroxybenzoic
606 acid, take up water dramatically above 95 % RH when approaching 100 % RH (Huff Hartz et al., 2006;
607 Chan et al., 2008; Rastak et al., 2017), which is clear from model predictions, as demonstrated in Fig. 6
608 by application of Eq. (4). The predicted curve in the mixture's effective κ parameter may well capture
609 the change in hygroscopicity under such high RH conditions. Consequently, for a precise representation
610 of the hygroscopic growth behavior (e.g. HGF) at high RH (> 95 %) by the κ -Köhler model, the value of
611 κ would need to be varied. While a variable κ value is contrary to the attempted simplicity of the single-
612 parameter κ -Köhler model, it is at least advised to consider that κ values derived from HGF data at 80 %
613 or 90 % RH may not apply accurately for the calculation of CCN activation properties of such biomass
614 burning aerosols.

615 To summarize, there is small difference in hygroscopicity parameters between sub-saturated
616 measurement conditions at 90 % RH in the laboratory with HTDMA and supersaturated conditions using
617 CCN measurements, in agreement with the findings of other studies. At regional scale, in the dry and wet
618 period, the hygroscopic behavior in some extent of the Amazon rainforest is influenced significantly by
619 the biomass burning emissions, which enhances CCN activity and droplet number concentrations in
620 warm clouds in that region and influences the radiation balance and cloud life time (Pöschl et al., 2010).
621 Underestimation of organic surrogate component mass fractions in the mixed particles or organic:sulfate
622 mass ratios may be responsible for the slight differences in the determined κ parameters of the laboratory
623 and field measurements.

624

625 **4. Conclusions**

626 A number of field-based hygroscopicity studies about biomass burning aerosol focus on the growth
627 factors of mixtures at high RH (e.g. 90 % RH). However, less attention has been paid to the growth

628 behavior at low to moderate RH, limiting the database for accurate estimates of particles optical and
629 radiative properties over those lower RH ranges. However, this is a RH range in which water uptake or
630 release behavior demonstrates a considerable variability among different organic-inorganic systems. The
631 occurrence or suppression of a liquid-solid phase transition affects the physicochemical particle
632 properties in a relative narrow RH range, potentially leading to particles of different morphology and
633 physical states, affecting effective particle size and density. In this work, measurements and
634 thermodynamic equilibrium predictions for organic-inorganic aerosols related to components from
635 biomass burning emissions demonstrate a diversity of hygroscopic growth/shrinking behavior. For
636 example, in the case of aerosol mixtures containing levoglucosan and ammonium sulfate, the presence
637 of levoglucosan may cause the efflorescence of AS to occur at higher RH than in pure aqueous AS
638 particles-or it may completely suppress AS efflorescence, as observed for mixtures with a high
639 levoglucosan mass fraction. The growth curves predicted with an AIOMFAC-based thermodynamic
640 equilibrium model reproduce the observations in most cases reasonably well and we demonstrate the
641 usefulness of predictions with different assumptions about the physical state of the organic components
642 for the interpretation of experimental data, such as in the case of mixtures of 4-hydroxybenzoic acid and
643 ammonium sulfate. However, the accurate prediction of AS efflorescence or its suppression in mixed
644 particles is difficult. The E-AIM-predicted growth curves reproduce the measured hygroscopic behavior
645 relatively well for the consideration of the effect of 4-hydroxybenzoic acid on the hygroscopic behavior
646 of mixtures with ammonium sulfate, which leads to suppression of the ammonium sulfate efflorescence.
647 In the case of mixtures of humic acid and ammonium sulfate, continuous water desorption of aerosol
648 particles shows no significant effect on the efflorescence of ammonium sulfate. Also, as expected, there
649 is a clear reduction in the diameter growth factor of mixed systems, in comparison with that of pure AS
650 particles. In addition, the small difference of hygroscopicity parameters of mix-bio-dry and mix-bio-wet
651 systems between measured data in the laboratory using HTDMA and the field using CCN activity
652 measurements is due to the similar O:C ratios of organic surrogate compounds and ammonium sulfate
653 mass fractions used in the model mixtures when experimental κ data from sub- and super-saturated water
654 vapor conditions are compared.

655 The range of measurement-model comparisons presented in this study indicate that providing accurate
656 thermodynamic model predictions of the hygroscopic growth behavior of mixed organic-inorganic

657 systems remains a challenging problem. At moderate and low RH, where aerosol solution phases become
658 highly concentrated, step-like or gradual crystallization and related solid-liquid equilibria may occur with
659 high sensitivity to the organic/inorganic mass ratio and the chemical nature of the mixture constituents.
660 To further improve thermodynamic equilibrium models for the prediction of hygroscopicity and phase
661 transitions, controlled laboratory experiments with single solutes and/or with mixed organic-inorganic
662 systems of known phase state will be useful to constrain model parameters. Ideally, such measurements
663 should cover the high, intermediate and low RH ranges under humidification and dehumidification
664 conditions.

665

666 **Data availability.** The measured results underlying this publication are available under the
667 <https://pan.baidu.com/s/1jIDxAcA>.

668

669 **Acknowledgements.** This project was supported by the Strategic Priority Research Program (B) of the
670 Chinese Academy of Sciences (Grant No. XDB05010400), the National Key Research and Development
671 Program of China (2016YFC0202202), and the National Natural Science Foundation of China (Contract
672 No. 91544227, 41227805). The authors would like to thank J. Hong and Z. B. Wang for comments and
673 suggestions for improvement of the manuscript.

674

675 **Reference**

676 Altaf, M. B., Zuend, A., and Freedman, M. A.: Role of nucleation mechanism on the size dependent
677 morphology of organic aerosol, *Chemical communications*, 52, 9220-9223, 2016.

678 Andreae, M. O. and Gelencser, A.: Black carbon or brown carbon? The nature of light-absorbing
679 carbonaceous aerosols, *Atmospheric Chemistry and Physics*, 6, 3131-3148, 2006.

680 Apelblat, A.: The vapour pressures of saturated aqueous solutions of potassium bromide, ammonium
681 sulfate, copper (II) sulfate, iron (II) sulfate, and manganese (II) dichloride, at temperatures from 283 K
682 to 308 K, *The Journal of Chemical Thermodynamics*, 25, 1513-1520, 1993.

683 Arnold, S., Emmons, L., Monks, S., Law, K. S., Ridley, D., Turquety, S., Tilmes, S., Thomas, J. L.,

684 Bouarar, I., and Flemming, J.: Biomass burning influence on high-latitude tropospheric ozone and
685 reactive nitrogen in summer 2008: a multi-model analysis based on POLMIP simulations, *Atmospheric*
686 *Chemistry and Physics*, 15, 6047-6068, 2015.

687 Artaxo, P., Martins, J. V., Yamasoe, M. A., Procópio, A. S., Pauliquevis, T. M., Andreae, M. O., Guyon,
688 P., Gatti, L. V., and Leal, A. M. C.: Physical and chemical properties of aerosols in the wet and dry
689 seasons in Rondônia, Amazonia, *Journal of Geophysical Research: Atmospheres*, 107, LBA 49-41-LBA
690 49-14, 2002.

691 Atkinson, D. B., Radney, J. G., Lum, J., Kolesar, K. R., Cziczo, D. J., Pekour, M. S., Zhang, Q., Setyan,
692 A., Zelenyuk, A., and Cappa, C. D.: Aerosol optical hygroscopicity measurements during the 2010
693 CARES campaign, *Atmospheric Chemistry and Physics*, 15, 4045-4061, 2015.

694 Bahadur, R., Praveen, P. S., Xu, Y. Y., and Ramanathan, V.: Solar absorption by elemental and brown
695 carbon determined from spectral observations, *Proceedings of the National Academy of Sciences of the*
696 *United States of America*, 109, 17366-17371, 2012.

697 Beyer, K. D., Friesen, K., Bothe, J. R., and Palet, B.: Phase Diagrams and Water Activities of Aqueous
698 Dicarboxylic Acid Systems of Atmospheric Importance, *Journal of Physical Chemistry A*, 112, 11704-
699 11713, 10.1021/jp805985t, 2008.

700 Bodsworth, A., Zobrist, B., and Bertram, A. K.: Inhibition of efflorescence in mixed organic-inorganic
701 particles at temperatures less than 250 K, *Physical chemistry chemical physics : PCCP*, 12, 12259-12266,
702 2010.

703 Bones, D. L., Reid, J. P., Lienhard, D. M., and Krieger, U. K.: Comparing the mechanism of water
704 condensation and evaporation in glassy aerosol, *Proceedings of the National Academy of Sciences*, 109,
705 11613-11618, 2012.

706 Boucher Olivier and David, R.: *Clouds and Aerosols*, PICC, 2013.

707 Brooks, S. D., DeMott, P. J., and Kreidenweis, S. M.: Water uptake by particles containing humic
708 materials and mixtures of humic materials with ammonium sulfate, *Atmos. Environ.*, 38, 1859-1868,
709 2004.

710 Carrico, C. M., Petters, M. D., Kreidenweis, S. M., Collett, J. L., Engling, G., and Malm, W. C.: Aerosol
711 hygroscopicity and cloud droplet activation of extracts of filters from biomass burning experiments,
712 *Journal of Geophysical Research*, doi:10.1029/2007JD009274, 2008.

713 Chan, M. N. and Chan, C. K.: Hygroscopic properties of two model humic-like substances and their
714 mixtures with inorganics of atmospheric importance, *Environmental Science & Technology*, 37, 5109-
715 5115, 2003.

716 Chan, M. N., Choi, M. Y., Ng, N. L., and Chan, C. K.: Hygroscopicity of water-soluble organic
717 compounds in atmospheric aerosols: Amino acids and biomass burning derived organic species,
718 *Environmental Science & Technology*, 39, 1555-1562, 2005.

719 Chan, M. N., Kreidenweis, S. M., and Chan, C. K.: Measurements of the Hygroscopic and Deliquescence
720 Properties of Organic Compounds of Different Solubilities in Water and Their Relationship with Cloud
721 Condensation Nuclei Activities, *Environmental Science & Technology*, 42, 3602-3608, 2008.

722 Chan, M. N. C. a. C. K.: Mass transfer effects in hygroscopic measurements of aerosol particles,
723 *Atmospheric Chemistry and Physics*, 2005. 2005.

724 Cheung, H. H. Y., Yeung, M. C., Li, Y. J., Lee, B. P., and Chan, C. K.: Relative Humidity-Dependent
725 HTDMA Measurements of Ambient Aerosols at the HKUST Supersite in Hong Kong, China, *Aerosol
726 Science and Technology*, 49, 643-654, 2015.

727 Cheng, Y. F., Su, H., Rose, D., Gunthe, S. S., Berghof, M., Wehner, B., Achtert, P., Nowak, A., Takegawa,
728 N., Kondo, Y., Shiraiwa, M., Gong, Y. G., Shao, M., Hu, M., Zhu, T., Zhang, Y. H., Carmichael, G. R.,
729 Wiedensohler, A., Andreae, M. O., and Pöschl, U.: Size-resolved measurement of the mixing state of soot
730 in the megacity Beijing, China: diurnal cycle, aging and parameterization, *Atmospheric Chemistry and
731 Physics*, 12, 4477-4491, 2012.

732 Choi, M. Y. and Chan, C. K.: The effects of organic species on the hygroscopic behaviors of inorganic
733 aerosols, *Environmental science & technology*, 36, 2422-2428, 2002.

734 Ciarelli, G., Aksoyoglu, S., Crippa, M., Jimenez, J. L., Nemitz, E., Sellegri, K., Äijälä, M., Carbone, S.,
735 Mohr, C., O'Dowd, C., Poulain, L., Baltensperger, U., and Prévôt, A. S. H.: Evaluation of European air
736 quality modelled by CAMx including the volatility basis set scheme, *Atmos. Chem. Phys.*, 16, 10313-

737 10332, 2016.

738 Ciobanu, V. G., Marcolli, C., Krieger, U. K., Zuend, A., and Peter, T.: Efflorescence of ammonium sulfate
739 and coated ammonium sulfate particles: evidence for surface nucleation, *The Journal of Physical*
740 *Chemistry A*, 114, 9486-9495, 2010.

741 Clegg, S. L. and Seinfeld, J. H.: Thermodynamic models of aqueous solutions containing inorganic
742 electrolytes and dicarboxylic acids at 298.15 K. 2. Systems including dissociation equilibria, *Journal of*
743 *Physical Chemistry A*, 110, 5718-5734, 2006.

744 Clegg, S. L. and Wexler, A. S.: Densities and Apparent Molar Volumes of Atmospherically Important
745 Electrolyte Solutions. 1. The Solutes H₂SO₄, HNO₃, HCl, Na₂SO₄, NaNO₃, NaCl, (NH₄)₂SO₄,
746 NH₄NO₃, and NH₄Cl from 0 to 50 degrees C, Including Extrapolations to Very Low Temperature and
747 to the Pure Liquid State, and NaHSO₄, NaOH, and NH₃ at 25 degrees C, *Journal of Physical Chemistry*
748 *A*, 115, 3393-3460, 2011a.

749 Clegg, S. L. and Wexler, A. S.: Densities and apparent molar volumes of atmospherically important
750 electrolyte solutions. 2. The systems H⁽⁺⁾-HSO₄⁽⁻⁾-SO₄⁽²⁻⁾-H₂O from 0 to 3 mol kg⁽⁻¹⁾ as a function of
751 temperature and H⁽⁺⁾-NH₄⁽⁺⁾-HSO₄⁽⁻⁾-SO₄⁽²⁻⁾-H₂O from 0 to 6 mol kg⁽⁻¹⁾ at 25 degrees C using a Pitzer ion
752 interaction model, and NH₄HSO₄-H₂O and (NH₄)₃H(SO₄)₂-H₂O over the entire concentration range, *The*
753 *journal of physical chemistry. A*, 115, 3461-3474, 2011b.

754 Decesari, S., Fuzzi, S., Facchini, M. C., Mircea, M., Emblico, L., Cavalli, F., Maenhaut, W., Chi, X.,
755 Schkolnik, G., Falkovich, A., Rudich, Y., Claeys, M., Pashynska, V., Vas, G., Kourtchev, I., Vermeylen,
756 R., Hoffer, A., Andreae, M. O., Tagliavini, E., Moretti, F., and Artaxo, P.: Characterization of the organic
757 composition of aerosols from Rondonia, Brazil, during the LBA-SMOCC 2002 experiment and its
758 representation through model compounds, *Atmospheric Chemistry and Physics*, 6, 375-402, 2006.

759 Denjean, C., Formenti, P., Picquet-Varrault, B., Pangui, E., Zapf, P., Katrib, Y., Giorio, C., Tapparo, A.,
760 Monod, A., and Temime-Roussel, B.: Relating hygroscopicity and optical properties to chemical
761 composition and structure of secondary organic aerosol particles generated from the ozonolysis of α -
762 pinene, *Atmospheric Chemistry and Physics*, 15, 3339-3358, 2015.

763 Dick, W. D., Saxena, P., and McMurry, P. H.: Estimation of water uptake by organic compounds in

764 submicron aerosols measured during the Southeastern Aerosol and Visibility Study, *Journal of*
765 *Geophysical Research-Atmospheres*, 105, 1471-1479, 2000.

766 Dusek, U., Frank, G. P., Massling, A., Zeromskiene, K., Iinuma, Y., Schmid, O., Helas, G., Hennig, T.,
767 Wiedensohler, A., and Andreae, M. O.: Water uptake by biomass burning aerosol at sub- and
768 supersaturated conditions: closure studies and implications for the role of organics, *Atmospheric*
769 *Chemistry and Physics*, 11, 9519-9532, 2011.

770 Engelhart, G. J., Hennigan, C. J., Miracolo, M. A., Robinson, A. L., and Pandis, S. N.: Cloud
771 condensation nuclei activity of fresh primary and aged biomass burning aerosol, *Atmospheric Chemistry*
772 *and Physics*, 12, 7285-7293, 2012.

773 Favez, O., Alfaro, S. C., Sciare, J., Cachier, H., and Abdelwahab, M. M.: Ambient measurements of light-
774 absorption by agricultural waste burning organic aerosols, *Journal of Aerosol Science*, 40, 613-620, 2009.

775 Feng, Y., Chen, Y., Guo, H., Zhi, G., Xiong, S., Li, J., Sheng, G., and Fu, J.: Characteristics of organic
776 and elemental carbon in PM_{2.5} samples in Shanghai, China, *Atmospheric Research*, 92, 434-442, 2009.

777 Frosch, M., Prisle, N. L., Bilde, M., Varga, Z., and Kiss, G.: Joint effect of organic acids and inorganic
778 salts on cloud droplet activation, *Atmospheric Chemistry and Physics*, 11, 3895-3911, 10.5194/acp-11-
779 3895-2011, 2011.

780 Gilman, J. B., Lerner, B. M., Kuster, W. C., Goldan, P. D., Warneke, C., Veres, P. R., Roberts, J. M., de
781 Gouw, J. A., Burling, I. R., and Yokelson, R. J.: Biomass burning emissions and potential air quality
782 impacts of volatile organic compounds and other trace gases from fuels common in the US, *Atmos. Chem.*
783 *Phys.*, 15, 13915-13938, 2015.

784 Gupta, D., Eom, H. J., Cho, H. R., and Ro, C. U.: Hygroscopic behavior of NaCl–MgCl₂ mixture
785 particles as nascent sea-spray aerosol surrogates and observation of efflorescence during humidification,
786 *Atmos. Chem. Phys.*, 15, 11273-11290, 2015.

787 Hanford, K. L., Mitchem, L., Reid, J. P., Clegg, S. L., Topping, D. O., and McFiggans, G. B.:
788 Comparative thermodynamic studies of aqueous glutaric acid, ammonium sulfate and sodium chloride
789 aerosol at high humidity, *Journal of Physical Chemistry A*, 112, 9413-9422, 10.1021/jp802520d, 2008.

790 Hecobian, A., Zhang, X., Zheng, M., Frank, N., Edgerton, E. S., and Weber, R. J.: Water-Soluble Organic
791 Aerosol material and the light-absorption characteristics of aqueous extracts measured over the
792 Southeastern United States, *Atmospheric Chemistry and Physics*, 10, 5965-5977, 2010.

793 Hegg, D. A., Warren, S. G., Grenfell, T. C., Doherty, S. J., and Clarke, A. D.: Sources of light-absorbing
794 aerosol in arctic snow and their seasonal variation, *Atmospheric Chemistry and Physics*, 10, 10923-10938,
795 2010.

796 Hodas, N., Zuend, A., Mui, W., Flagan, R., and Seinfeld, J.: Influence of particle-phase state on the
797 hygroscopic behavior of mixed organic-inorganic aerosols, *Atmospheric Chemistry and Physics*, 15,
798 5027-5045, 2015.

799 Hodas, N., Zuend, A., Schilling, K., Berkemeier, T., Shiraiwa, M., Flagan, R. C., and Seinfeld, J. H.:
800 Discontinuities in hygroscopic growth below and above water saturation for laboratory surrogates of
801 oligomers in organic atmospheric aerosols, *Atmos. Chem. Phys.*, doi: 10.5194/acp-16-12767-2016, 2016.

802 Jacobson, M. Z.: Effects of biomass burning on climate, accounting for heat and moisture fluxes, black
803 and brown carbon, and cloud absorption effects, *Journal of Geophysical Research-Atmospheres*, 119,
804 8980-9002, 2014.

805 Jedelský Jiri, L. i. H. e. y., Pavel Hynčica, and Ivan and Cibulka: Partial molar volumes of organic
806 solutes in water. IV. Benzoic and hydroxybenzoic acids at temperatures from T D 298 K to T D 498 K
807 and pressures up to 30 MPa, *J. Chem. Thermodynamics*, 32, 11, 2000.

808 Jing, B., Tong, S., Liu, Q., Li, K., Wang, W., Zhang, Y., and Ge, M.: Hygroscopic behavior of
809 multicomponent organic aerosols and their internal mixtures with ammonium sulfate, *Atmospheric*
810 *Chemistry and Physics*, 16, 4101-4118, 2016.

811 Kim, J., Ahlm, L., Yli-Juuti, T., Lawler, M., Keskinen, H., Tröstl, J., Schobesberger, S., Duplissy, J.,
812 Amorim, A., Bianchi, F., Donahue, N. M., Flagan, R. C., Hakala, J., Heinritzi, M., Jokinen, T., Kürten,
813 A., Laaksonen, A., Lehtipalo, K., Miettinen, P., Petäjä, T., Rissanen, M. P., Rondo, L., Sengupta, K.,
814 Simon, M., Tomé, A., Williamson, C., Wimmer, D., Winkler, P. M., Ehrhart, S., Ye, P., Kirkby, J., Curtius,
815 J., Baltensperger, U., Kulmala, M., Lehtinen, K. E. J., Smith, J. N., Riipinen, I., and Virtanen, A.:
816 Hygroscopicity of nanoparticles produced from homogeneous nucleation in the CLOUD experiments,

817 Atmos. Chem. Phys., 16, 293-304, 2016.

818 Kiss, G., Tombácz, E., and Hansson, H.-C.: Surface Tension Effects of Humic-Like Substances in the
819 Aqueous Extract of Tropospheric Fine Aerosol, *Journal of Atmospheric Chemistry*, 50, 279-294, 2005.

820 Koop, T., Bookhold, J., Shiraiwa, M., and Poschl, U.: Glass transition and phase state of organic
821 compounds: dependency on molecular properties and implications for secondary organic aerosols in the
822 atmosphere, *Physical Chemistry Chemical Physics*, 13, 19238-19255, 2011.

823 Konovalov, I. B., Beekmann, M., Berezin, E. V., Petetin, H., Mielonen, T., Kuznetsova, I. N., and Andreae,
824 M. O.: The role of semi-volatile organic compounds in the mesoscale evolution of biomass burning
825 aerosol: a modeling case study of the 2010 mega-fire event in Russia, *Atmos. Chem. Phys.*, 15, 13269-
826 13297, 2015.

827 Laborde, M., Crippa, M., Tritscher, T., Juranyi, Z., Decarlo, P. F., Temime-Roussel, B., Marchand, N.,
828 Eckhardt, S., Stohl, A., Baltensperger, U., Prevot, A. S. H., Weingartner, E., and Gysel, M.: Black carbon
829 physical properties and mixing state in the European megacity Paris, *Atmospheric Chemistry and Physics*,
830 13, 5831-5856, 2013.

831 Lack, D. A., Bahreni, R., Langridge, J. M., Gilman, J. B., and Middlebrook, A. M.: Brown carbon
832 absorption linked to organic mass tracers in biomass burning particles, *Atmospheric Chemistry and*
833 *Physics*, 13, 2415-2422, 2013.

834 Lack, D. A., Bahreni, R., Langridge, J. M., Gilman, J. B., and Middlebrook, A. M.: Brown carbon
835 absorption linked to organic mass tracers in biomass burning particles, *Atmospheric Chemistry and*
836 *Physics*, 13, 2415-2422, 2013.

837 Lack, D. A., Langridge, J. M., Bahreini, R., Cappa, C. D., Middlebrook, A. M., and Schwarz, J. P.: Brown
838 carbon and internal mixing in biomass burning particles, *Proceedings of the National Academy of*
839 *Sciences of the United States of America*, 109, 14802-14807, 2012.

840 Lawson, S. J., Keywood, M. D., Galbally, I. E., Gras, J. L., Caine, J. M., Cope, M. E., Krummel, P. B.,
841 Fraser, P. J., Steele, L. P., Bentley, S. T., Meyer, C. P., Ristovski, Z., and Goldstein, A. H.: Biomass
842 burning emissions of trace gases and particles in marine air at Cape Grim, Tasmania, *Atmos. Chem. Phys.*,

843 15, 13393-13411, 2015.

844 Lee, Y. N.: Airborne measurement of inorganic ionic components of fine aerosol particles using the
845 particle-into-liquid sampler coupled to ion chromatography technique during ACE-Asia and TRACE-P,
846 Journal of Geophysical Research, doi:10.1029/2002JD003265, 2003.

847 Lei, T., Zuend, A., Wang, W. G., Zhang, Y. H., and Ge, M. F.: Hygroscopicity of organic compounds from
848 biomass burning and their influence on the water uptake of mixed organic ammonium sulfate aerosols,
849 Atmospheric Chemistry and Physics, 14, 1-20, 2014.

850 Lienhard, D. M., Bones, D. L., Zuend, A., Krieger, U. K., Reid, J. P., and Peter, T.: Measurements of
851 thermodynamic and optical properties of selected aqueous organic and organic-inorganic mixtures of
852 atmospheric relevance, The journal of physical chemistry. A, 116, 9954-9968, 2012.

853 Liu, B. Y. H., Pui, D. Y. H., and Rubow, K. L. a. S., W.W.: ELECTROSTATIC EFFECTS IN AEROSOL
854 SAMPLING AND FILTRATION, Arm. occup. Hyg., 29, 251-269, 1985.

855 Liu, J. M., Scheuer, E., Dibb, J., Ziemba, L. D., Thornhill, K. L., Anderson, B. E., Wisthaler, A., Mikoviny,
856 T., Devi, J. J., Bergin, M., and Weber, R. J.: Brown carbon in the continental troposphere, Geophysical
857 Research Letters, 41, 2191-2195, 2014.

858 Liu, Q., Jing, B., Peng, C., Tong, S., Wang, W., and Ge, M.: Hygroscopicity of internally mixed multi-
859 component aerosol particles of atmospheric relevance, Atmos. Environ., 125, 69-77, 2016.

860 Malm, W. C. and Kreidenweis, S. M.: The effects of models of aerosol hygroscopicity on the
861 apportionment of extinction, Atmos. Environ., 31, 1965-1976, 1997.

862 MAN NIN CHAN, A. K. Y. L., AND and CHAN, C. K.: Responses of Ammonium Sulfate Particles
863 Coated with Glutaric Acid to Cyclic Changes in Relative Humidity: Hygroscopicity and Raman
864 Characterization, Environ.Sci.Technol., 40, 6893-6989, 2006.

865 Man Nin Chan, C. K. C.: Mass transfer effects on the hygroscopic growth of ammonium sulfate particles
866 with a water-insoluble coating, Atmos. Environ., doi: 10.1016/j.atmosenv.2007.01.047, 2007.

867 Marcolli, C. and Peter, T.: Water activity in polyol/water systems: new UNIFAC parameterization, Atmos.

868 Chem. Phys., 5, 1545-1555, 2005.

869 Marshall, F. H., Miles, R. E. H., Song, Y.-C., Ohm, P. B., Power, R. M., Reid, J. P., and Dutcher, C. S.:
870 Diffusion and reactivity in ultraviscous aerosol and the correlation with particle viscosity, Chemical
871 Science, 7, 1298-1308, 2016.

872 Martin, M., Tritscher, T., Juranyi, Z., Heringa, M. F., Sierau, B., Weingartner, E., Chirico, R., Gysel, M.,
873 Prevot, A. S. H., Baltensperger, U., and Lohmann, U.: Hygroscopic properties of fresh and aged wood
874 burning particles, Journal of Aerosol Science, 56, 15-29, 2013.

875 Mikhailov, E., Vlasenko, S., Rose, D., and Pöschl, U.: Mass-based hygroscopicity parameter interaction
876 model and measurement of atmospheric aerosol water uptake, Atmospheric Chemistry and Physics, 13,
877 717-740, 2013.

878 Mochida, M. and Kawamura, K.: Hygroscopic properties of levoglucosan and related organic compounds
879 characteristic to biomass burning aerosol particles, Journal of Geophysical Research-Atmospheres,
880 doi:10.1029/2004JD004962, 2004.

881 Moosmuller, H., Chakrabarty, R. K., and Arnott, W. P.: Aerosol light absorption and its measurement: A
882 review, Journal of Quantitative Spectroscopy & Radiative Transfer, 110, 844-878, 2009.

883 Paglione, M., Saarikoski, S., Carbone, S., Hillamo, R., Facchini, M. C., Finessi, E., Giulianelli, L.,
884 Carbone, C., Fuzzi, S., Moretti, F., Tagliavini, E., Swietlicki, E., Stenstrom, K. E., Prevot, A. S. H.,
885 Massoli, P., Canaragatna, M., Worsnop, D., and Decesari, S.: Primary and secondary biomass burning
886 aerosols determined by proton nuclear magnetic resonance (¹H-NMR) spectroscopy during the 2008
887 EUCAARI campaign in the Po Valley (Italy), Atmospheric Chemistry and Physics, 14, 5089-5110, 2014.

888 Pajunoja, A, AT Lambe, J Hakala, N Rastak, MJ Cummings, JF Brogan, L Hao, M Paramonov, J
889 Hong, NL Prisle, J Malila, S Romakkaniemi, KEJ Lehtinen, A Laaksonen, M Kulmala, P Massoli, TB
890 Onasch, NM Donahue, I Riipinen, P Davidovits, DR Worsnop, T Petäjä, and A
891 Virtanen (2015), Adsorptive uptake of water by semisolid secondary organic aerosols. Geophys. Res.
892 Lett., 42, 3063–3068. doi: 10.1002/2015GL063142.

893 Ovadnevaite, J., Zuend, A., Laaksonen, A., Sanchez, K. J., Roberts, G., Ceburnis, D., Decesari, S.,

894 Rinaldi, M., Hodas, N., Facchini, M. C., Seinfeld, J. H., and O' Dowd, C.: Surface tension prevails over
895 solute effect in organic-influenced cloud droplet activation, *Nature*, 546, 637-641, 10.1038/nature22806,
896 2017.

897 Peng, C., Chan, M. N., and Chan, C. K.: The hygroscopic properties of dicarboxylic and multifunctional
898 acids: Measurements and UNIFAC predictions, *Environmental Science & Technology*, 35, 4495-4501,
899 2001.

900 Petters, M. D. and Kreidenweis, S. M.: A single parameter representation of hygroscopic growth and
901 cloud condensation nucleus activity, *Atmos. Chem. Phys.*, 7, 1961-1971, 2007.

902 Pöhlker, M. L., Pöhlker, C., Ditas, F., Klimach, T., Hrabe de Angelis, I., Araújo, A., Brito, J., Carbone,
903 S., Cheng, Y., and Chi, X.: Long-term observations of cloud condensation nuclei in the Amazon rain
904 forest—Part 1: Aerosol size distribution, hygroscopicity, and new model parametrizations for CCN
905 prediction, *Atmospheric Chemistry and Physics*, 16, 15709-15740, 2016.

906 Powelson, M. H., Espelien, B. M., Hawkins, L. N., Galloway, M. M., and De Haan, D. O.: Brown Carbon
907 Formation by Aqueous-Phase Carbonyl Compound Reactions with Amines and Ammonium Sulfate,
908 *Environmental Science & Technology*, 48, 985-993, 2014.

909 Pratt, K. A., Murphy, S. M., Subramanian, R., DeMott, P. J., Kok, G. L., Campos, T., Rogers, D. C.,
910 Prenni, A. J., Heymsfield, A. J., Seinfeld, J. H., and Prather, K. A.: Flight-based chemical characterization
911 of biomass burning aerosols within two prescribed burn smoke plumes, *Atmospheric Chemistry and*
912 *Physics*, 11, 12549-12565, 2011.

913 Pratt, K. A. and Prather, K. A.: Aircraft measurements of vertical profiles of aerosol mixing states, *Journal*
914 *of Geophysical Research*, doi:10.1029/2009JD013150, 2010.

915 Rastak, N., Pajunoja, A., Acosta Navarro, J. C., Ma, J., Song, M., Partridge, D. G., Kirkevåg, A., Leong,
916 Y., Hu, W. W., Taylor, N. F., Lambe, A., Cerully, K., Bougiatioti, A., Liu, P., Krejci, R., Petäjä, T., Percival,
917 C., Davidovits, P., Worsnop, D. R., Ekman, A. M. L., Nenes, A., Martin, S., Jimenez, J. L., Collins, D.
918 R., Topping, D. O., Bertram, A. K., Zuend, A., Virtanen, A., and Riipinen, I.: Microphysical explanation
919 of the RH-dependent water affinity of biogenic organic aerosol and its importance for climate,
920 *Geophysical Research Letters*, doi: 10.1002/2017GL073056. 2017.

921 Reid, J. P., Dennis-Smith, B. J., Kwamena, N.-O. A., Miles, R. E. H., Hanford, K. L., and Homer, C.
922 J.: The morphology of aerosol particles consisting of hydrophobic and hydrophilic phases: hydrocarbons,
923 alcohols and fatty acids as the hydrophobic component, *Physical Chemistry Chemical Physics*, 13,
924 15559-15572, 2011.

925 Renbaum-Wolff, L., Song, M., Marcolli, C., Zhang, Y., Liu, P. F., Grayson, J. W., Geiger, F. M., Martin,
926 S. T., and Bertram, A. K.: Observations and implications of liquid-liquid phase separation at high relative
927 humidities in secondary organic material produced by α -pinene ozonolysis without inorganic salts,
928 *Atmos. Chem. Phys.*, 16, 7969-7979, 2016.

929 Rissler, J., Vestin, A., Swietlicki, E., Fisch, G., Zhou, J., Artaxo, P., and Andreae, M. O.: Size distribution
930 and hygroscopic properties of aerosol particles from dry-season biomass burning in Amazonia,
931 *Atmospheric Chemistry and Physics*, 6, 471-491, 2006.

932 Rizzo, L. V., Correia, A. L., Artaxo, P., Procopio, A. S., and Andreae, M. O.: Spectral dependence of
933 aerosol light absorption over the Amazon Basin, *Atmospheric Chemistry and Physics*, 11, 8899-8912,
934 2011.

935 Rose, D., Gunthe, S. S., Su, H., Garland, R. M., Yang, H., Berghof, M., Cheng, Y. F., Wehner, B., Achtert,
936 P., Nowak, A., Wiedensohler, A., Takegawa, N., Kondo, Y., Hu, M., Zhang, Y., Andreae, M. O., and
937 Poschl, U.: Cloud condensation nuclei in polluted air and biomass burning smoke near the mega-city
938 Guangzhou, China -Part 2: Size-resolved aerosol chemical composition, diurnal cycles, and externally
939 mixed weakly CCN-active soot particles, *Atmospheric Chemistry and Physics*, 11, 2817-2836, 2011.

940 Saarnio, K., Aurela, M., Timonen, H., Saarikoski, S., Teinila, K., Makela, T., Sofiev, M., Koskinen, J.,
941 Aalto, P. P., Kulmala, M., Kukkonen, J., and Hillamo, R.: Chemical composition of fine particles in fresh
942 smoke plumes from boreal wild-land fires in Europe, *Science of the Total Environment*, 408, 2527-2542,
943 2010.

944 Sadezky, A., Muckenhuber, H., Grothe, H., Niessner, R., and Poschl, U.: Raman micro spectroscopy of
945 soot and related carbonaceous materials: Spectral analysis and structural information, *Carbon*, 43, 1731-
946 1742, 2005.

947 Saleh, R., Hennigan, C. J., McMeeking, G. R., Chuang, W. K., Robinson, E. S., Coe, H., Donahue, N.

948 M., and Robinson, A. L.: Absorptivity of brown carbon in fresh and photo-chemically aged biomass-
949 burning emissions, *Atmospheric Chemistry and Physics*, 13, 7683-7693, 2013.

950 Saleh, R., Robinson, E. S., Tkacik, D. S., Ahern, A. T., Liu, S., Aiken, A. C., Sullivan, R. C., Presto, A.
951 A., Dubey, M. K., Yokelson, R. J., Donahue, N. M., and Robinson, A. L.: Brownness of organics in
952 aerosols from biomass burning linked to their black carbon content, *Nature Geoscience*, 7, 647-650, 2014.

953 Seinfeld, J. and Pandis, S.: *Atmospheric chemistry and physics*. Hoboken. NJ: Wiley, 2006.

954 Shantanu H. Jathar, A. M., Kekkey C. Barsabti, William E. Asher, James F, Pankow and Michael J.
955 Kleeman: Water uptake by organic aerosol and its influence on gas/particle partitioning of secondary
956 organic aerosol in the United States doi: 10.1016/j.atmosenv.2016.01.001, 2016.

957 Shiraiwa, M., Zuend, A., Bertram, A. K., and Seinfeld, J. H.: Gas-particle partitioning of atmospheric
958 aerosols: interplay of physical state, non-ideal mixing and morphology, *Physical Chemistry Chemical
959 Physics*, 15, 11441-11453, 2013.

960 Sjogren, S., Gysel, M., Weingartner, E., Baltensperger, U., Cubison, M. J., Coe, H., Zardini, A. A.,
961 Marcolli, C., Krieger, U. K., and Peter, T.: Hygroscopic growth and water uptake kinetics of two-phase
962 aerosol particles consisting of ammonium sulfate, adipic and humic acid mixtures, *Journal of Aerosol
963 Science*, 38, 157-171, 2007.

964 Smith, M. L., Bertram, A. K., and Martin, S. T.: Deliquescence, efflorescence, and phase miscibility of
965 mixed particles of ammonium sulfate and isoprene-derived secondary organic material, *Atmospheric
966 Chemistry and Physics*, 12, 9613-9628, 2012.

967 Song, M., Marcolli, C., Krieger, U. K., Zuend, A., and Peter, T.: Liquid-liquid phase separation and
968 morphology of internally mixed dicarboxylic acids/ammonium sulfate/water particles, *Atmospheric
969 Chemistry and Physics*, 12, 2691-2712, 2012.

970 Song, M., Marcolli, C., Krieger, U. K., Zuend, A., and Peter, T.: Liquid-liquid phase separation in aerosol
971 particles: Dependence on O:C, organic functionalities, and compositional complexity, *Geophysical
972 Research Letters*, 39, doi:10.1029/2012GL052807, 2012.

973 Srinivas, B. and Sarin, M. M.: Brown carbon in atmospheric outflow from the Indo-Gangetic Plain: Mass

974 absorption efficiency and temporal variability, *Atmos. Environ.*, 89, 835-843, 2014.

975 Srinivas, B. and Sarin, M. M.: Light absorbing organic aerosols (brown carbon) over the tropical Indian
976 Ocean: impact of biomass burning emissions, *Environmental Research Letters*, doi:10.1088/1748-
977 9326/8/4/044042, 2013.

978 Svenningsson, B., Rissler, J., Swietlicki, E., Mircea, M., Bilde, M., Facchini, M. C., Decesari, S., Fuzzi,
979 S., Zhou, J., Monster, J., and Rosenorn, T.: Hygroscopic growth and critical supersaturations for mixed
980 aerosol particles of inorganic and organic compounds of atmospheric relevance, *Atmospheric Chemistry
981 and Physics*, 6, 1937-1952, 2006.

982 Topping, D., McFiggans, G., and Coe, H.: A curved multi-component aerosol hygroscopicity model
983 framework: Part 1–Inorganic compounds, *Atmospheric Chemistry and Physics*, 5, 1205-1222, 2005.

984 Tuckermann, R. a. C., H. K.: The surface tension of aqueous solutions of some atmospheric water-soluble
985 organic compounds, *Atmos. Environ.*, 38, 6135-6138, 2004.

986 Väkevä, M., Kulmala, M., Stratmann, F., and Hämeri, K.: Field measurements of hygroscopic properties
987 and state of mixing of nucleation mode particles, *Atmospheric Chemistry and Physics*, 2, 55-66, 2002.

988 Veghte, D. P., Altaf, M. B., and Freedman, M. A.: Size dependence of the structure of organic aerosol,
989 *Journal of the American Chemical Society*, 135, 16046-16049, 2013.

990 Gonçalves, W. A., Machado, L. A. T., and Kirstetter, P.-E.: Influence of biomass aerosol on precipitation
991 over the Central Amazon: an observational study, *Atmos. Chem. Phys.*, doi: 10.5194/acp-15-6789-2015,
992 2015.

993 Wang, J., Cubison, M. J., Aiken, A. C., Jimenez, J. L., and Collins, D. R.: The importance of aerosol
994 mixing state and size-resolved composition on CCN concentration and the variation of the importance
995 with atmospheric aging of aerosols, *Atmospheric Chemistry and Physics*, 10, 7267-7283, 2010.

996 Wang, X., Heald, C. L., Ridley, D. A., Schwarz, J. P., Spackman, J. R., Perring, A. E., Coe, H., Liu, D.,
997 and Clarke, A. D.: Exploiting simultaneous observational constraints on mass and absorption to estimate
998 the global direct radiative forcing of black carbon and brown carbon, *Atmospheric Chemistry and Physics*,
999 14, 10989-11010, 2014.

1000 Whitehead, J. D., Darbyshire, E., Brito, J., Barbosa, H. M., Crawford, I., Stern, R., Gallagher, M. W.,
1001 Kaye, P. H., Allan, J. D., and Coe, H.: Biogenic cloud nuclei in the central Amazon during the transition
1002 from wet to dry season, *Atmospheric Chemistry and Physics*, 16, 9727-9743, 2016.

1003 Wu, Z. J., Zheng, J., Shang, D. J., Du, Z. F., Wu, Y. S., Zeng, L. M., Wiedensohler, A., and Hu, M.:
1004 Particle hygroscopicity and its link to chemical composition in the urban atmosphere of Beijing, China,
1005 during summertime, *Atmos. Chem. Phys.*, 16, 1123-1138, 2016.

1006 Yates III, L. M., Wandruszka, R.V.: Decontamination of polluted water by treatment with a crude humic
1007 acid blend, *Environmental Science and Technology*, 33, 2076-2080, 1999.

1008 You, Y. and Bertram, A. K.: Effects of molecular weight and temperature on liquid–liquid phase
1009 separation in particles containing organic species and inorganic salts, *Atmospheric Chemistry and*
1010 *Physics*, 15, 1351-1365, 2015.

1011 You, Y., Renbaum-Wolff, L., and Bertram, A. K.: Liquid–liquid phase separation in particles containing
1012 organics mixed with ammonium sulfate, ammonium bisulfate, ammonium nitrate or sodium chloride,
1013 *Atmospheric Chemistry and Physics*, 13, 11723-11734, 2013.

1014 Yuan Youa, L. R.-W., Marc Carreras-Sospedrab, Sarah J. Hannaa, Naruki Hiranumac, Saeid Kamald,,
1015 Mackenzie L. Smithe, X. Z., Rodney J. Weberf, John E. Shillingg, Donald Dabdubb, Scot T. Martine,h,1,,
1016 and Bertrama, a. A. K.: Images reveal that atmospheric particles can undergo liquid–liquid phase
1017 separations, *pnas*, 109, 13188-13193, 2012.

1018 Zamora, I. R., Tabazadeh, A., Golden, D. M., and Jacobson, M. Z.: Hygroscopic growth of common
1019 organic aerosol solutes, including humic substances, as derived from water activity measurements,
1020 *Journal of Geophysical Research: Atmospheres*, doi:10.1029/2011JD016067, 2011.

1021 Zardini, A. A., Sjogren, S., Marcolli, C., Krieger, U. K., Gysel, M., Weingartner, E., Baltensperger, U.,
1022 and Peter, T.: A combined particle trap/HTDMA hygroscopicity study of mixed inorganic/organic aerosol
1023 particles, *Atmospheric Chemistry and Physics*, 8, 5589-5601, 2008.

1024 Zawadowicz, M., Proud, S., Seppalainen, S., and Cziczo, D.: Hygroscopic and phase separation
1025 properties of ammonium sulfate/organics/water ternary solutions, *Atmospheric Chemistry and Physics*,

1026 15, 8975-8986, 2015.

1027 Zhang, Q., Jimenez, J. L., Canagaratna, M. R., Allan, J. D., Coe, H., Ulbrich, I., Alfarra, M. R., Takami,
1028 A., Middlebrook, A. M., Sun, Y. L., Dzepina, K., Dunlea, E., Docherty, K., DeCarlo, P. F., Salcedo, D.,
1029 Onasch, T., Jayne, J. T., Miyoshi, T., Shimonono, A., Hatakeyama, S., Takegawa, N., Kondo, Y., Schneider,
1030 J., Drewnick, F., Borrmann, S., Weimer, S., Demerjian, K., Williams, P., Bower, K., Bahreini, R., Cottrell,
1031 L., Griffin, R. J., Rautiainen, J., Sun, J. Y., Zhang, Y. M., and Worsnop, D. R.: Ubiquity and dominance
1032 of oxygenated species in organic aerosols in anthropogenically-influenced Northern Hemisphere
1033 midlatitudes, *Geophysical Research Letters*, doi:10.1029/2007GL029979, 2007.

1034 Zhang, S. L., Ma, N., Kecorius, S., Wang, P. C., Hu, M., Wang, Z. B., Größ, J., Wu, Z. J., and
1035 Wiedensohler, A.: Mixing state of atmospheric particles over the North China Plain, *Atmos. Environ.*,
1036 125, Part A, 152-164, 2016.

1037 Zhong, M. and Jang, M.: Dynamic light absorption of biomass-burning organic carbon photochemically
1038 aged under natural sunlight, *Atmospheric Chemistry and Physics*, 14, 1517-1525, 2014.

1039 Zuend, A., Marcolli, C., Booth, A. M., Lienhard, D. M., Soonsin, V., Krieger, U. K., Topping, D. O.,
1040 McFiggans, G., Peter, T., and Seinfeld, J. H.: New and extended parameterization of the thermodynamic
1041 model AIOMFAC: calculation of activity coefficients for organic-inorganic mixtures containing carboxyl,
1042 hydroxyl, carbonyl, ether, ester, alkenyl, alkyl, and aromatic functional groups, *Atmospheric Chemistry
1043 and Physics*, 11, 9155-9206, 2011.

1044 Zuend, A., Marcolli, C., Luo, B. P., and Peter, T.: A thermodynamic model of mixed organic-inorganic
1045 aerosols to predict activity coefficients, *Atmospheric Chemistry and Physics*, 8, 4559-4593, 2008.

1046 Zuend, A., Marcolli, C., Peter, T., and Seinfeld, J. H.: Computation of liquid-liquid equilibria and phase
1047 stabilities: implications for RH-dependent gas/particle partitioning of organic-inorganic aerosols,
1048 *Atmospheric Chemistry and Physics*, 10, 7795-7820, 2010.

1049 Zuend, A. and Seinfeld, J. H.: Modeling the gas-particle partitioning of secondary organic aerosol: the
1050 importance of liquid-liquid phase separation, *Atmospheric Chemistry and Physics*, 12, 3857-3882, 2012.

1051

1052 **Table 1.** Substances and their physical properties used in this work.

Chemical compound	Chemical formula	Molar Mass [g mol ⁻¹]	Density in solid or liquid state [g cm ⁻³]	Solubility g/100cm ³ H ₂ O	Solution surface tension [J m ⁻²]	Manufacturer
Ammonium sulfate	(NH ₄) ₂ SO ₄	132.140	1.770 ^a (solid), 1.550 ^a (liquid)	74.400(at 20°C)	0.072(0.001-10mg/mL)	Alfa Aesar, 99.95%
Levogluconan	C ₆ H ₁₀ O ₅	126.100	1.618 ^b (solid) 1.512 ^b (liquid)		0.073 ^c (0.01-10mg/mL)	Aldrich, 99%
4-Hydroxybenzoic acid	C ₇ H ₆ O ₃	138.100	1.460(solid) 1.372 ^f (liquid)	0.675(at 25°C)	0.070 ^g (>10mg/mL)	Alfa Aesar, 99.99%
Humic acid		NA	0.800 ^h (solid)	NA	NA	Aldrich, 99%

1053 ^aClegg and Wexler, (2011);1054 ^bLienhard et al, (2012);1055 ^cTuckermann and Cammenga (2004) at 293K;1056 ^fJedelsky et al, (2000);1057 ^gKiss et al, (2005);1058 ^hYates III and Wandruszka, (1999);

1059

1060

1061

1062

1063

1064

1065

1066

1067

1068

1069

1070 **Table 2.** The chemical composition of biomass-burning model mixtures studied given as mass
1071 percentages (wt %).

Mixture name	Levoglucosan	4-Hydroxybenzoic acid	Humic acid	Ammonium sulfate
Mix-bio-dry	87.2%	9.2%	1.5%	2.1%
Mix-bio-wet	68.0%	26.0%	3.0%	3.0%

1072

1073

1074

1075

1076

1077

1078

1079

1080

1081

1082

1083

1084

1085

1086

1087

1088

1089

1090 **Table 3.** Coefficients (c_1 , c_2 , c_3) of the fitted growth factor parameterization (Eq. 5) as follows:

Chemical compounds	c_1	c_2	c_3
Levogluconan	0.12868746	0.36582023	-0.39840382
4-Hydroxybenzoic acid	-1.389967E-01	2.325586E-01	-9.891943E-02
Humic acid	-1.618304E-02	2.202483E-01	2.005134E-02

1091

1092

1093

1094

1095

1096

1097

1098

1099

1100

1101

1102

1103

1104

1105

1106

1107

1108 **Table 4:** Experimental studies of organic and ammonium sulfate (AS) deliquescence and efflorescence
 1109 RH from this work and previous studies at 298K.

Signal compound/Mixture	Organic mass fraction (%)	Deliquescence relative humidity of AS or organic in the mixed particle	Efflorescence relative humidity of AS or organic in the mixed particle
Levogluconan	-	80% ^{a*} 82.8% ^b	< 4% ^{a*}
Levogluconan+AS	25	80%	45%
	50	-	-
	75	-	-
4-hydroxybenzoic acid	-	> 97% ^{a*}	< 4% ^{a*}
	25	80%	35%
4-Hydroxybenzoic acid+AS	50	80%	25%
	75	80%	-
	-	-	-
Humic acid	-	-	-
	20	80%	35%
Humic acid+AS	50	80%	35%
	75	80%	35%

1110 ^{*}is the DRH and ERH of pure organic components.

1111 ^aMochida and Kawamura. (2004)

1112 ^bZamora et al. (2011)

1113

1114

1115

1116

1117

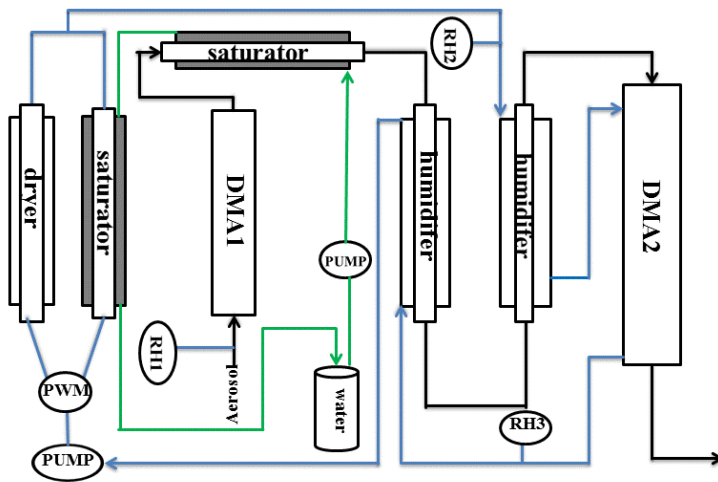

1118

1119 **Figure 1.** Schematic of the hygroscopicity tandem different mobility analyzer (HTDMA) system. the
 1120 sheath flow, aerosol flow, and water flow have been represented by the blue, black, green line,
 1121 respectively. PWM: Pulse Width Modulator circuit.

1122

1123

1124

1125

1126

1127

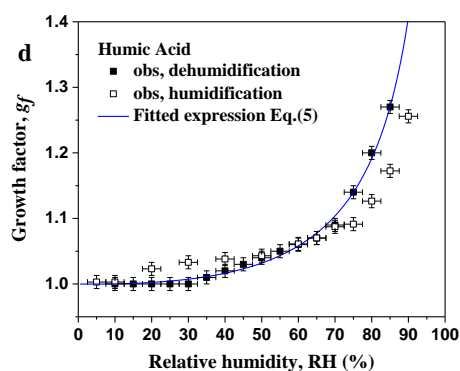
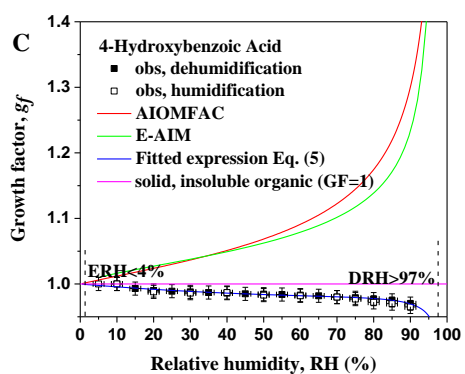
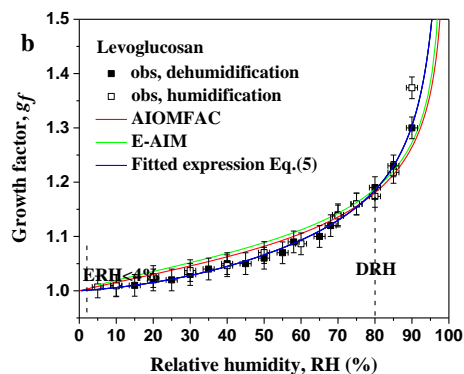
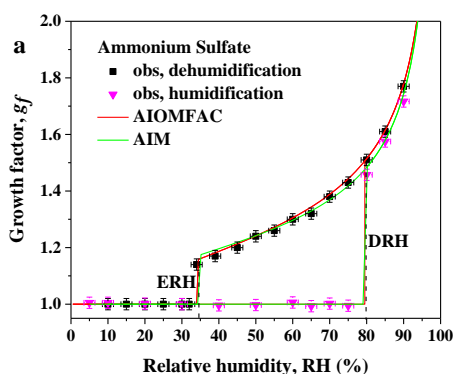

1128

1129

1130 **Figure 2.** Hygroscopic growth, deliquescence and efflorescence of aerosol particles. Hygroscopic growth
 1131 factors of (a) ammonium sulfate (AS), (b) levoglucosan, (c) 4-hydroxybenzoic acid, and (d) humic acid
 1132 aerosol particles with dry diameter of 100 nm (open, black square). In this study, the green curves show
 1133 E-AIM predictions, and the red curves the AIOMFAC predictions, and the blue lines the fitted expression
 1134 (Eq. 5).

1135

1136

1137

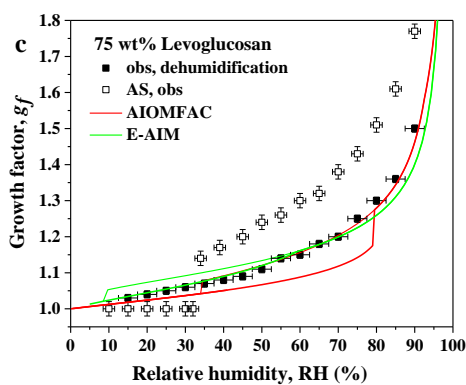
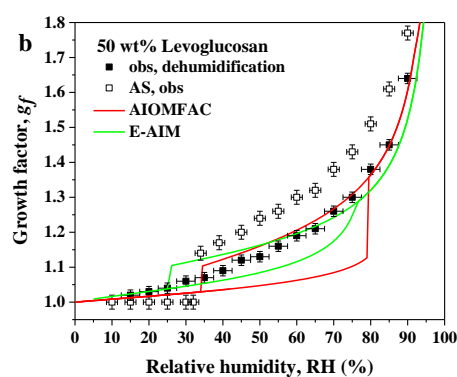
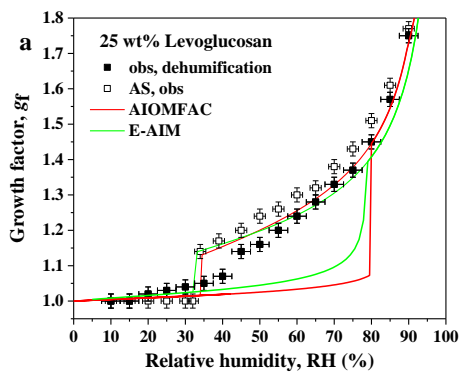

1138

1139

1140 **Figure 3.** Hygroscopic growth, efflorescence of aerosol particles, and model predictions represent the
 1141 diameter growth factor during dehydration experiments in the range from 90 % to 5 % RH at 298.15 K.
 1142 (a,b,c). Hygroscopic growth curves of mixtures consisting of levoglucosan and ammonium sulfate (solid
 1143 symbols) at three different dry state mass fraction for particles of an initial dry diameter of 100 nm at RH
 1144 < 5 %) as compared to that of pure ammonium sulfate (open symbols, “AS, obs”). AIOMFAC-based
 1145 model predictions for bulk systems are shown in red, E-AIM predictions are shown in green.

1146

1147

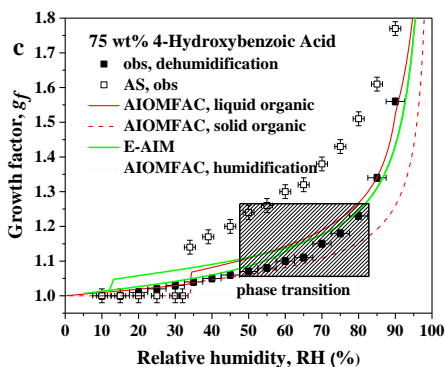
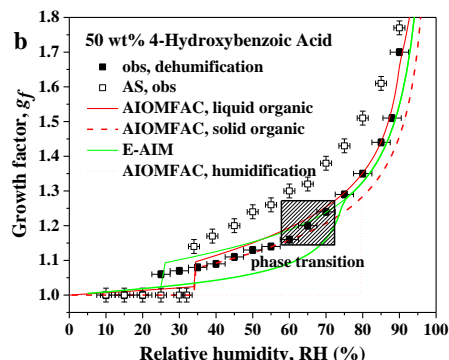
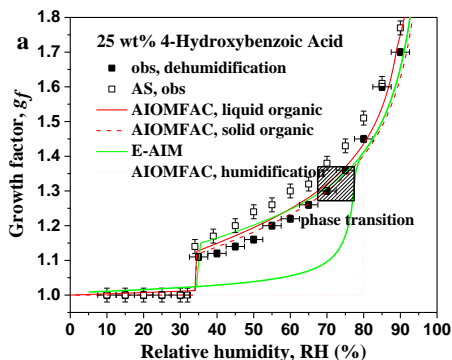

1148

1149

1150 **Figure 4.** Hygroscopic growth factors, efflorescence of behavior, and model predications for dehydration
 1151 experiments in the range from 90 % to 5 % RH at 298.15 K. **(a,b,c)** hygroscopic growth curves of
 1152 mixtures consisting of 4-hydroxybenzoic acid and ammonium sulfate (solid symbols) at three different
 1153 dry state mass fraction (initial dry diameter of 100 nm at RH < 5 %) as compared to that of pure
 1154 ammonium sulfate (open symbols). AIOMFAC-based model predications for bulk systems are shown in
 1155 red, E-AIM-predictions are shown in green for the case of assuming that 4-hydroxybenzoic acid remains
 1156 in the liquid state. Shaded rectangle: RH range of gradual crystallization of 4-hydroxybenzoic acid.

1157

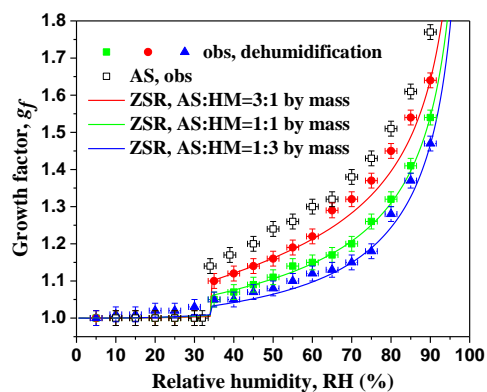

1158

1159 **Figure 5.** Hygroscopic growth factors, efflorescence of aerosol particles/constituents consisting of humic
 1160 acid and ammonium sulfate at three different dry state mass fractions with initial dry diameter of 100 nm
 1161 at $RH < 5\%$ as compared to that of pure ammonium sulfate (open symbols). Colored curves: ZSR
 1162 predictions of diameter growth factors for dry particle compositions corresponding to the experimental
 1163 data during dehumidification in the range from 90 % to 5 % RH at 298.15 K.

1164

1165

1166

1167

1168

1169

1170

1171

1172

1173

1174

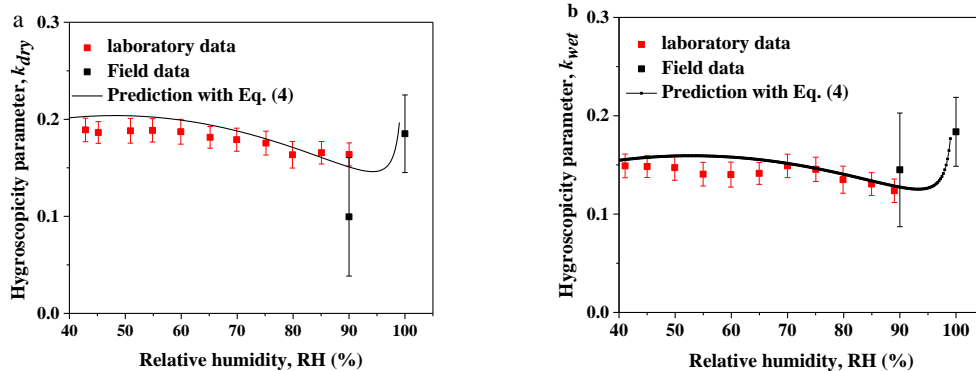

1175

1176 **Figure 6.** Hygroscopicity parameter, κ , representing mixed aerosol particles consisting of organic
 1177 surrogate components and ammonium sulfate at different periods (initial dry diameter of 100 nm at RH
 1178 $< 5\%$). The black curves in panels (a, b) show the κ prediction from Eq. (4) with HGF_{mix} calculated by
 1179 Eq. (6) using component volume fractions and the HGF of the individual mixture components from a fit
 1180 to the laboratory data (using Eq.5). the black symbols and error bars show field data from the Amazon
 1181 during the dry and wet periods at conditions of water vapor sub-saturation (HTDMA measurement) and
 1182 super-saturation (κ_{CNN}) (Whitehead et al., 2016; Pöhlker et al., 2006).

1183

1184

1185