

An improved inlet for precisely measuring the atmospheric Ar/N₂ ratio

T. W. Blaine, R. F. Keeling, and W. J. Paplawsky

Scripps Institution of Oceanography, University of California, San Diego, La Jolla, CA 92093-0244, USA

Received: 19 September 2005 – Accepted: 7 November 2005 – Published: 21 November 2005

Correspondence to: T. W. Blaine (tblaine@ucsd.edu)

© 2005 Author(s). This work is licensed under a Creative Commons License.

An improved inlet for measuring the atmospheric Ar/N₂ ratio

T. W. Blaine et al.

Title Page

Abstract

Introduction

Conclusions

References

Tables

Figures

⏪

⏩

◀

▶

Back

Close

Full Screen / Esc

Print Version

Interactive Discussion

EGU

Abstract

The atmospheric Ar/N₂ ratio is expected to be useful as a tracer of air-sea heat exchange, but this application has been hindered in part due to sampling artifacts. Here we show that the variability in $\delta(\text{Ar}/\text{N}_2)$ due to thermal fractionation at the inlet can be on the order of 40–80 per meg, and we introduce the use of an aspirated solar shield that successfully minimizes such fractionation. The data collected using this new inlet have a mean diurnal cycle of 1.0 per meg or less, suggesting that any residual thermal fractionation effect is reduced to this level.

1. Introduction

The atmospheric Ar/N₂ ratio is potentially useful as a tracer for air-sea heat exchange and for testing oceanic and atmospheric models (Battle et al., 2003; Keeling et al., 2004). As the ocean warms, the solubilities of Ar and N₂ decrease, and the ocean releases these gases to the atmosphere. The reverse happens as the ocean cools. The atmospheric Ar/N₂ ratio changes in response to these fluxes because Ar is more soluble than N₂ (Weiss, 1970). A close coupling between air-sea heat flux and changes in atmospheric Ar/N₂ ratio is expected over a wide range of space and time scales, including seasonally and interannually.

The changes in the atmospheric Ar/N₂ ratio are very small, so the ratio is conveniently expressed as the deviation from a reference according to

$$\delta(\text{Ar}/\text{N}_2) = \frac{(\text{Ar}/\text{N}_2)_{\text{sample}}}{(\text{Ar}/\text{N}_2)_{\text{reference}}} - 1, \quad (1)$$

where $\delta(\text{Ar}/\text{N}_2)$ is typically multiplied by 10⁶ and expressed in “per meg” units. An increase of one mole of Ar in 10⁶ moles of air corresponds to a 107 per meg change in $\delta(\text{Ar}/\text{N}_2)$, whereas a similar increase in N₂ corresponds to a –1.3 per meg change

An improved inlet for measuring the atmospheric Ar/N₂ ratio

T. W. Blaine et al.

Title Page

Abstract

Introduction

Conclusions

References

Tables

Figures

◀

▶

◀

▶

Back

Close

Full Screen / Esc

Print Version

Interactive Discussion

An improved inlet for measuring the atmospheric Ar/N₂ ratio

T. W. Blaine et al.

[Title Page](#)[Abstract](#)[Introduction](#)[Conclusions](#)[References](#)[Tables](#)[Figures](#)[⏪](#)[⏩](#)[◀](#)[▶](#)[Back](#)[Close](#)[Full Screen / Esc](#)[Print Version](#)[Interactive Discussion](#)

in the ratio. The Ar/N₂ ratio has been observed to vary seasonally by 10–20 per meg in peak-to-peak amplitude in mid- and high-latitude areas due to seasonal changes in ocean heat storage (Battle et al., 2003; Keeling et al., 2004). The annual-mean ratio is also predicted to vary with a latitudinal mean gradient by 1–3 per meg due to meridional oceanic heat transport, and the ratio is expected to be increasing by 2–3 per meg per decade due to long-term ocean warming. These predictions remain to be confirmed, however, due to the difficulty of the measurements (Battle et al., 2003; Keeling et al., 2004; Blaine, 2005).

We are presently measuring the Ar/N₂ ratio in flask air samples using a mass spectrometer (Isoprime) with a custom-built inlet (Keeling et al., 2004) and which achieves a precision of ~10 per meg on a 10-s integration (Keeling et al., 2004) and 2–3 per meg for a 10-min average. In our lab, the achieved replicate precision on flask samples is around 11 per meg; it is evident that sampling artifacts at both the point of collection and in the lab are contributing to the flask imprecision (Keeling et al., 2004). Similar problems have been identified in other labs (Battle et al., 2003).

Changes in Ar/N₂ ratio are difficult to measure, in part because the expected signals can easily be masked by sampling artifacts, such as fractionation by thermal diffusion, pressure diffusion, or diffusion through orifices (Keeling et al., 1998, Langenfelds, 2005). A thermal gradient of 0.1°C, for example, can lead to a 24 per meg difference in the Ar/N₂ ratio, whereas a gravitational gradient would give a 5 per meg difference over a 10 cm height (Keeling et al., 2004).

A prevalent problem involves thermal fractionation at the air intake. Solar heating or night-time radiative cooling can cause a gas intake to be at a different temperature than the ambient air. The air entering the intake can thus be fractionated by thermal diffusion relative to the surrounding atmosphere. The effect was first noted by Manning (2001), who reported variation of 20–30 per meg in continuous O₂/N₂ measurements on an hourly time scale with a flow rate of 100 ml/min, which would be expected to be about four times larger in Ar/N₂. Thermal fractionation at the intake is expected to vary on seasonal time scales and from site to site (Manning, 2001), and it seems possible

the observed differences in annual-mean Ar/N₂ between stations may be dominated by such artifacts (Battle et al., 2003; Keeling et al., 2004). It has been shown that using a larger sampling flow rate may reduce the effect (M. Bender, personal communication), but it is not clear that this procedure completely eliminates the potential sampling biases.

2. Testing of an aspirated, shielded inlet

In late 2003, we began using the mass spectrometer system (Keeling et al., 2004) not only for flask measurements but also for direct analysis of air drawn from the land end of the Scripps pier. The inlet extends horizontally about 1 m from the south side of the pier and is positioned at the height of the hand rail. The pier abuts a retaining wall supporting a bluff above the beach, and the inlet is located about 10 m above the beach and 3–4 m horizontally from the retaining wall. A Teflon diaphragm pump (KNF) located in the laboratory pulls air through 600 ft of 0.6 cm OD Synflex tubing (also known as Dekoron or Dekabon) and through a cold trap at about –80°C in order to freeze out all water. The location of the pump downstream of the cold trap helps to minimize condensation in the lines and to reduce the amount of damage to the pump caused by salt and water. Air is pumped at a rate of 300 ml/min, with no tee junctions in the design upstream of the point where reference gases are introduced. To correct for instrument drift, ambient air data is compared against a working gas, derived from a compressed air tank, for 10 min of each hour. See Blaine (2005) for more details.

We initially tested an intake, designed to minimize solar heating, consisting of a glass tube about 25 cm long placed under a white plastic shade. Over a period of ten consecutive days from 26 December 2003 to 5 January 2004, while using the glass inlet, the measured Ar/N₂ ratio varied over 40 per meg. High values were correlated with low winds and no solar radiation; low values were correlated with low winds and strong solar radiation. When the wind speed climbed above about 5 m s⁻¹, the values were much more consistent regardless of the solar intensity (see Fig. 1). These results sug-

An improved inlet for measuring the atmospheric Ar/N₂ ratio

T. W. Blaine et al.

Title Page

Abstract

Introduction

Conclusions

References

Tables

Figures

⏪

⏩

◀

▶

Back

Close

Full Screen / Esc

Print Version

Interactive Discussion

An improved inlet for measuring the atmospheric Ar/N₂ ratio

T. W. Blaine et al.

[Title Page](#)[Abstract](#)[Introduction](#)[Conclusions](#)[References](#)[Tables](#)[Figures](#)[⏪](#)[⏩](#)[◀](#)[▶](#)[Back](#)[Close](#)[Full Screen / Esc](#)[Print Version](#)[Interactive Discussion](#)

gest that, in spite of our efforts, thermal fractionation was still occurring at a significant level. During the day when the inlet is heated by solar radiation, thermal fractionation would lead to lower Ar/N₂ ratios, whereas at night, when the inlet cools radiatively, thermal fractionation would lead to higher Ar/N₂ ratios. When the wind is high, the radiative heating or cooling is less so the effect is reduced.

In order to further reduce thermal fractionation at the inlet, we employed an aspirated radiation shield (R. M. Young 43408) commonly used in weather stations to protect meteorological instruments from solar heating (Fig. 2). The shield is formed of two concentric intake tubes with a canopy shade, through which air is drawn at a flow of 3.4–7.6 m per second by a downstream fan. The shield, which is designed to house a meteorological sensor (e.g. thermometer), was used here to house the intake of the Synflex tubing, which we located approximately 5 cm above the base of the intake tubes. The Synflex tubing exited the junction box at the top of the radiation shield (see Fig. 2).

We tested this new setup over several days by switching on an hourly basis between two intake lines, one placed inside the aspirated radiation shield as described above and the other left unprotected but oriented downward (see Fig. 3). Results from a selected period of 24 h are shown in Fig. 4. Whereas a pronounced diurnal cycle of around 80 per meg is evident in the air sampled without the shield, no comparable cycle is noticeable in the air sampled with the shielded intake. The shielded intake exhibited only quasi-random variations of order ±4 per meg (based on hourly averages).

To provide a more sensitive measure of the performance of the aspirated intake, we computed the average diurnal cycle in Ar/N₂ ratio over an extended period. Between 1 June 2004, and 31 May 2005, the instrument was run on a semi-continuous basis using the aspirated solar shield at the inlet. We examined the 75 days of data in which we have 24 hourly measurements. We removed the daily mean value from each day's data and then averaged the 75 available points for each of the 24 h in a day. Figure 5 shows that the average peak-to-peak diurnal cycle has an amplitude of ~1.0 per meg, from which we conclude that any thermal fractionation effect at the inlet due to diurnal

An improved inlet for measuring the atmospheric Ar/N₂ ratioT. W. Blaine et al.

heating and cooling is at or below this level. Part of this remaining diurnal signal is likely due to other causes. One such example is the effect of carbon monoxide (CO⁺) in the mass spectrometer, which has the same mass as N₂. CO⁺ can be derived either from ambient CO or from fragments of CO₂ produced in the ionization process. As the wind shifts from a strong sea breeze during the day to a weaker land breeze at night, CO₂ tends to collect, with an average maximum concentration between 4 and 5 AM. Although we correct our measurements for the CO₂-derived CO⁺ contamination, the correction may not fully account for the effect and does not account for any contribution of ambient CO, which is also likely to have a diurnal cycle similar to that of CO₂.

3. Conclusions

The installation of an aspirated solar shield which protects the inlet from solar radiation and generates a continuous air flow over the inlet has minimized diurnal thermal fractionation at the inlet to 1.0 per meg or less. This new inlet has permitted estimation of the seasonal peak-to-peak $\delta(\text{Ar}/\text{N}_2)$ cycle of 9–10 per meg at the La Jolla pier station in semi-continuous measurements (Blaine, 2005).

Using an aspirated shield may also be advantageous for avoiding artifacts in flask sampling. Flask samples are typically collected at higher flows (2000–5000 ml min⁻¹) and therefore are less susceptible to inlet fractionation compared to the continuous measurements shown here. Nevertheless, there are indications from the larger-than-expected differences in annual-mean Ar/N₂ between stations and the larger-than-expected short-term variability that inlet fractionation is still relevant. O₂/N₂ is four times less sensitive to thermal fractionation compared to Ar/N₂ and has signals that are five to ten times larger. However, inlet fractionation could be interfering with certain subtle signals in O₂/N₂ measurements, such as the gradients between stations. Use of aspirated shields would help to eliminate any such artifacts.

Acknowledgements. This material is based upon work supported by the National Science Foundation under Grant Nos. 0000923 and 0330096, and NOAA Office of Global Programs

[Title Page](#)[Abstract](#)[Introduction](#)[Conclusions](#)[References](#)[Tables](#)[Figures](#)[⏪](#)[⏩](#)[◀](#)[▶](#)[Back](#)[Close](#)[Full Screen / Esc](#)[Print Version](#)[Interactive Discussion](#)

under Grant No. NA77RJ0453A. T. W. Blaine was also supported by NDSEG (1999–2002) and STAR EPA (2003–2005) graduate fellowships. Any opinions, findings, and conclusions or recommendations expressed in this material are those of the authors and do not necessarily reflect the views of the National Science Foundation.

5 References

Battle, M., Bender, M., Hendricks, M. B., Ho, D. T., Mika, R., McKinley, G., Fan, S.-M., Blaine, T., and Keeling, R. F.: Measurements and models of the atmospheric Ar/N₂ ratio, *Geophys. Res. Lett.*, 30, doi:10.1029/2003GL017411, 2003.

Blaine, T. W.: Continuous measurements of the atmospheric Ar/N₂ ratio as a tracer of air-sea heat flux: models, methods, and data, PhD thesis, University of California, San Diego, 2005.

Keeling, R. F., Blaine, T., Paplawsky, B., Katz, L., Atwood, C., and Brockwell, T.: Measurement of changes in atmospheric Ar/N₂ ratio using a rapid-switching, single-capillary mass spectrometer system, *Tellus*, 56B, 322–388, 2004.

Langenfelds, R. L., van der Schoot, M. V., Francey, R. J., Steele, L. P., Schmidt, M., and Mukai, H.: Modification of air standard composition by diffusive and surface processes, *J. Geophys. Res.-Atmos.*, 110, doi:10.1029/2004JD005482, 2005.

Manning, A. C.: Temporal variability of atmospheric oxygen from both continuous measurements and a flask sampling network: Tools for studying the global carbon cycle, PhD thesis, University of California, San Diego, 2001.

Weiss, R. F.: The solubility of nitrogen, oxygen, and argon in water and seawater, *Deep-Sea Res.*, 17, 721–735, 2001.

An improved inlet for measuring the atmospheric Ar/N₂ ratio

T. W. Blaine et al.

Title Page

Abstract

Introduction

Conclusions

References

Tables

Figures

⏪

⏩

◀

▶

Back

Close

Full Screen / Esc

Print Version

Interactive Discussion

An improved inlet for measuring the atmospheric Ar/N₂ ratioT. W. Blaine et al.

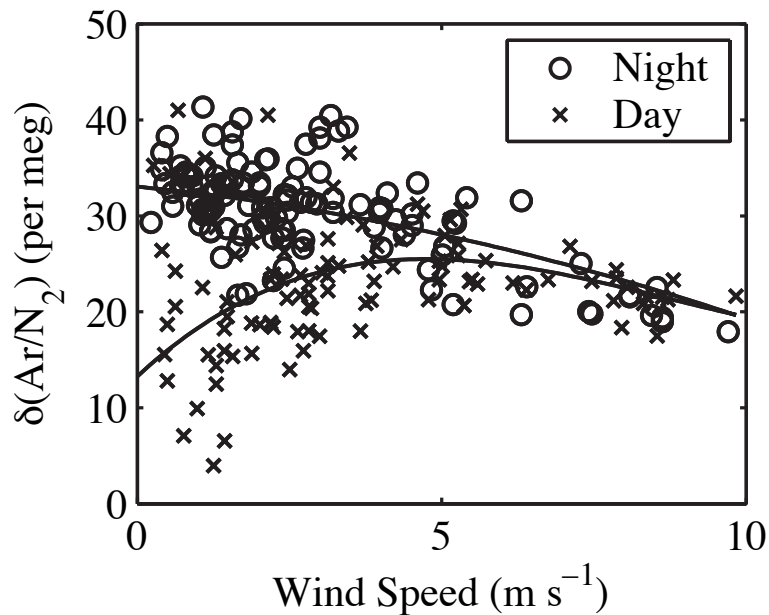

Fig. 1. Measured Ar/N₂ ratios versus ambient wind speed measured on the Scripps pier, La Jolla, CA, from 26 December 2003–5 January 2004. The data are separated into daytime and nighttime data based on the measured photosynthetically active radiation (PAR). The lines are cubic fits to the daytime and nighttime data.

[Title Page](#)[Abstract](#)[Introduction](#)[Conclusions](#)[References](#)[Tables](#)[Figures](#)[◀](#)[▶](#)[◀](#)[▶](#)[Back](#)[Close](#)[Full Screen / Esc](#)[Print Version](#)[Interactive Discussion](#)

**An improved inlet for
measuring the
atmospheric Ar/N₂
ratio**T. W. Blaine et al.

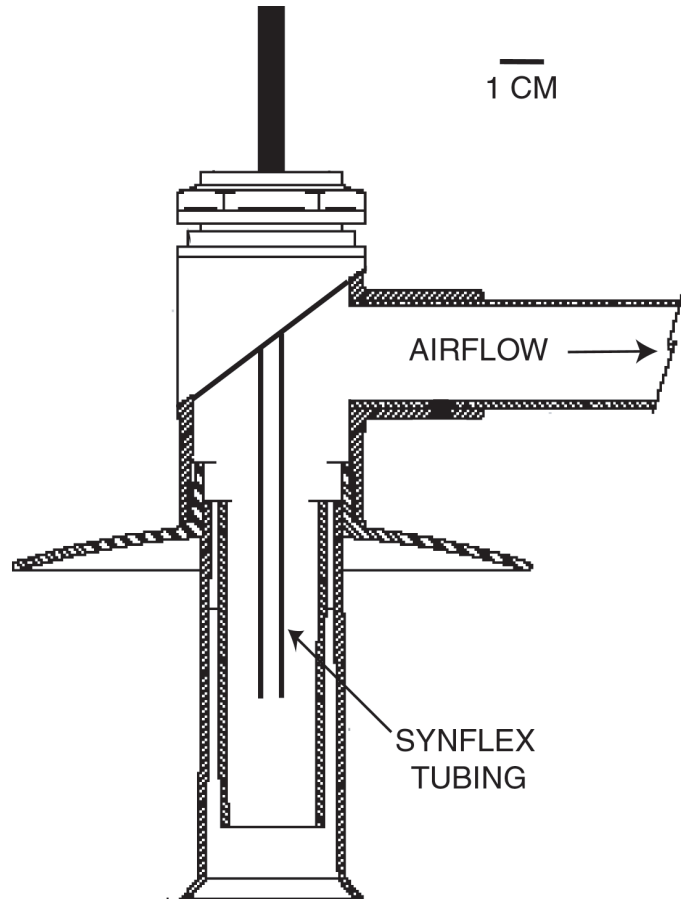

Fig. 2. Diagram of the inlet of the aspirated radiation shield (R. M. Young 43408) used for the air intake with our Synflex tubing positioned inside it.

[Title Page](#)[Abstract](#)[Introduction](#)[Conclusions](#)[References](#)[Tables](#)[Figures](#)[◀](#)[▶](#)[◀](#)[▶](#)[Back](#)[Close](#)[Full Screen / Esc](#)[Print Version](#)[Interactive Discussion](#)

An improved inlet for measuring the atmospheric Ar/N₂ ratio

T. W. Blaine et al.



Fig. 3. Photo showing the setup of the two-intake test.

Title Page

Abstract

Introduction

Conclusions

References

Tables

Figures

⏪

⏩

◀

▶

Back

Close

Full Screen / Esc

Print Version

Interactive Discussion

An improved inlet for measuring the atmospheric Ar/N₂ ratioT. W. Blaine et al.

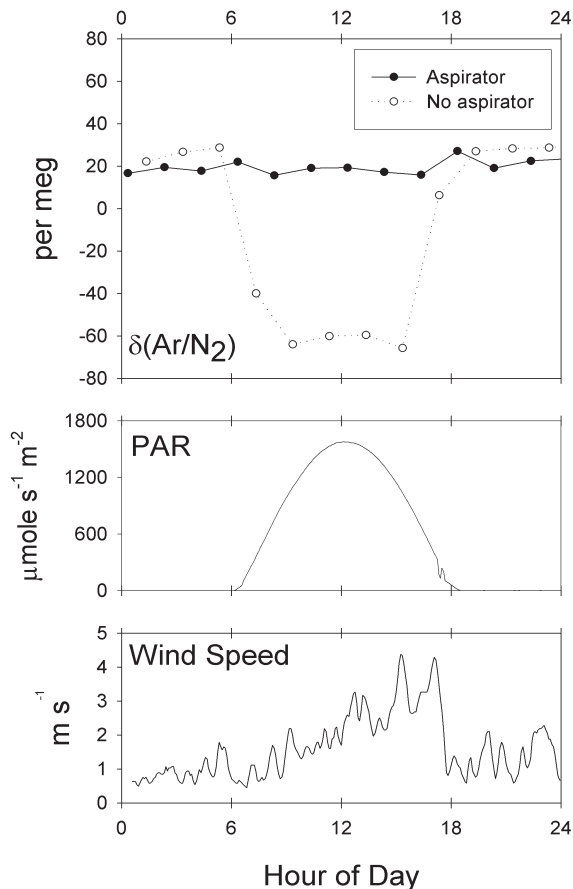

Fig. 4. Data from 28 March 2004. Every other hour the analyzed air is collected with an aspirated inlet or with an inlet of exposed Synflex tubing. The top panel shows the hourly average $\delta(\text{Ar}/\text{N}_2)$ values. The bottom panels are weather variables measured on the Scripps pier: photosynthetically active radiation (PAR) and wind speed.

[Title Page](#)[Abstract](#)[Introduction](#)[Conclusions](#)[References](#)[Tables](#)[Figures](#)[◀](#)[▶](#)[◀](#)[▶](#)[Back](#)[Close](#)[Full Screen / Esc](#)[Print Version](#)[Interactive Discussion](#)

An improved inlet for measuring the atmospheric Ar/N₂ ratioT. W. Blaine et al.

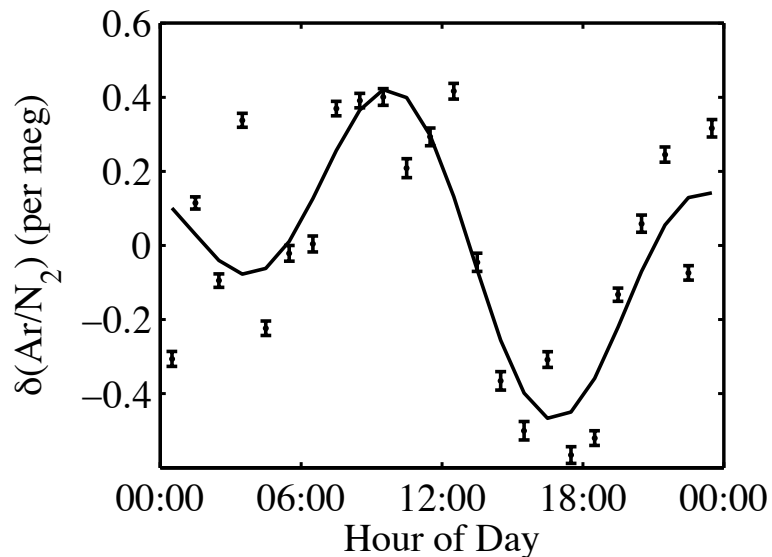

Fig. 5. Average diurnal cycle from semi-continuous data between 1 June 2004 and 31 May 2005. Within this period, we have 75 days in which we have 24 hourly determinations. We remove the daily mean and then average all 75 points for each hour of the day.

[Title Page](#)[Abstract](#)[Introduction](#)[Conclusions](#)[References](#)[Tables](#)[Figures](#)[◀](#)[▶](#)[◀](#)[▶](#)[Back](#)[Close](#)[Full Screen / Esc](#)[Print Version](#)[Interactive Discussion](#)