

Supplement of Atmos. Chem. Phys. Discuss., 15, 4117–4143, 2015
<http://www.atmos-chem-phys-discuss.net/15/4117/2015/>
doi:10.5194/acpd-15-4117-2015-supplement
© Author(s) 2015. CC Attribution 3.0 License.



Supplement of

Formation of hydroxyl radicals from photolysis of secondary organic aerosol material

K. M. Badali et al.

Correspondence to: S. Zhou (szhou@chem.utoronto.ca)

Supplementary Information

SOA Collection using Flow Tube

Secondary organic aerosol samples were also collected using a flow tube setup with a headspace bubbler providing the organic precursor (Figure S1). The flow tube SOA source was chosen for the peroxide stability studies to collect a high mass of particles rapidly. The dark, glass flow tube has dimensions of 60 cm in length, 3.74 cm in inner radius, with a volume of 2.64 L. All flows are reported under standard pressure and temperature conditions and were controlled by mass flow controllers (MFC) which were calibrated using an air flow calibrator (Giliblator-2, Sensidyne Instrumentation). Ozone was generated by flowing air over a 185 nm mercury pen-ray lamp, with a flow rate of 150 sccm (MFC 1). Nitrogen passed through a glass bubbler containing the VOC precursor ((-)- α -pinene, $\geq 99\%$, Sigma-Aldrich ; (R)-(+)-Limonene, 97%, Sigma-Aldrich) at a rate of 10 sccm (MFC 2). The bubbler was chilled at $-7\text{ }^{\circ}\text{C}$ for α -pinene experiments, and $2\text{ }^{\circ}\text{C}$ for limonene experiments. A carrier flow of clean air was added to the VOC flow after the bubbler at 25 sccm (MFC 3). An excess dilution flow of 1500 sccm of clean air was incorporated into the flows through a needle valve, with an open vent in the line before the air mixed with the ozone flow. This excess flow is used to supply extra air to the flow tube in the case of fluctuations in the other flows, ensuring that the total flow through the flow tube remains 1 slpm. The ozone and VOC flows were introduced to the top of the flow tube using a custom-made stainless steel T-fitting that prevented mixing until the flows reached the body of the flow tube. The flow rate through the flow tube was held at 1000 sccm using a pump (MFC 4). Aerosol samples were collected on supported polytetrafluoroethylene (PTFE) filters (Zefluor, Pall Life Sciences, 47 mm diameter, 2.0 μm pore size). Filter samples for stability experiments were collected for 2 hours, with approximately 500 μg of SOA generated. The amount of ozone entering the flow tube was periodically measured using an ozone analyzer (model 49C, Thermo Environmental Instruments Inc.). Approximately 1700 ppb of ozone was introduced to the flow tube, while an excess of 870 ppb of ozone was detected at the exit of the flow tube. Based on the consumption of ozone, it is estimated that approximately 830 ppb of α -pinene and limonene are consumed within the flow tube. The mass loadings of SOA within the flow tube were 3500 and 5000 $\mu\text{g}/\text{m}^3$ for α -pinene and limonene experiments, respectively.

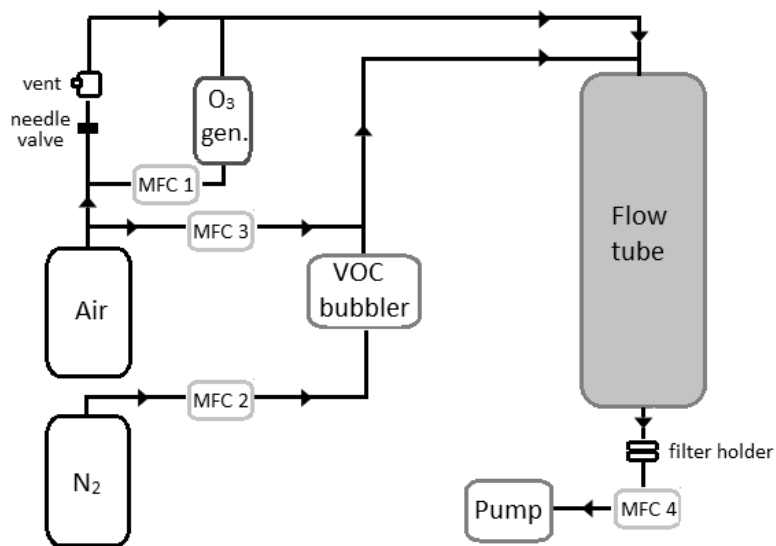
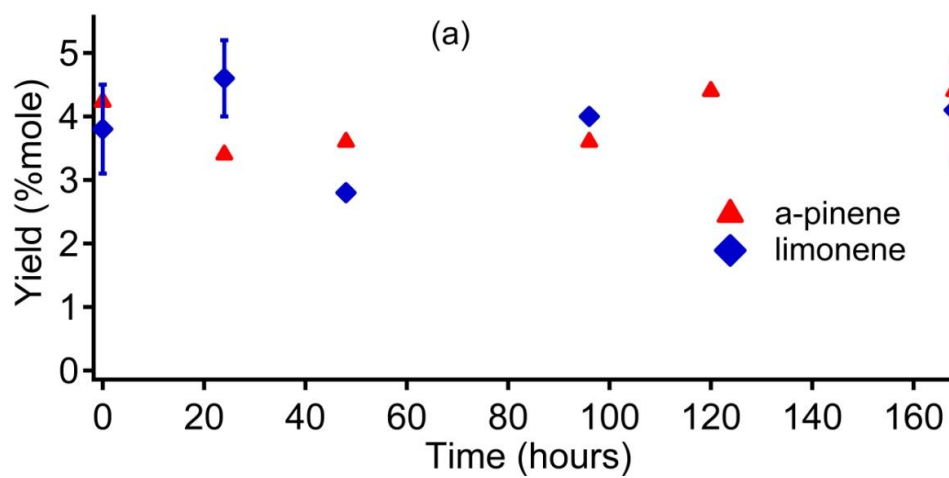

Figure S1. Simplified schematic of flow tube set up for SOA generation and collection.



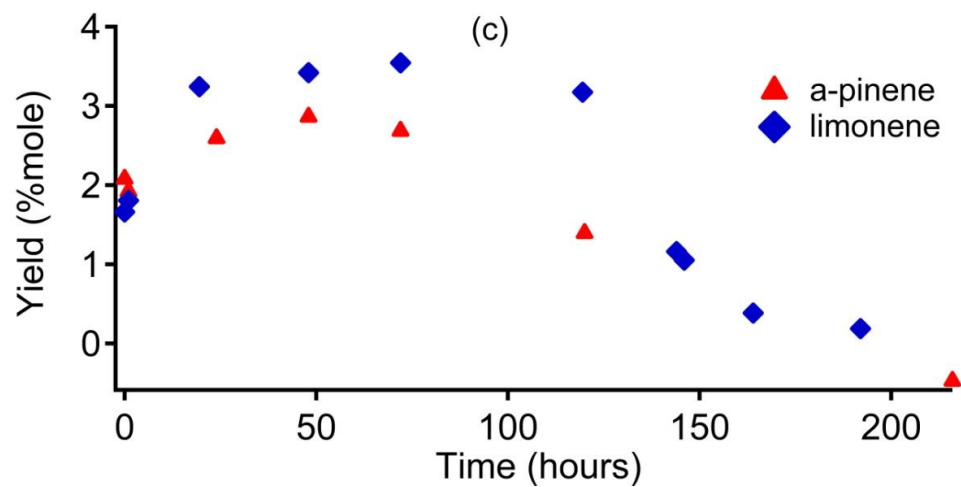
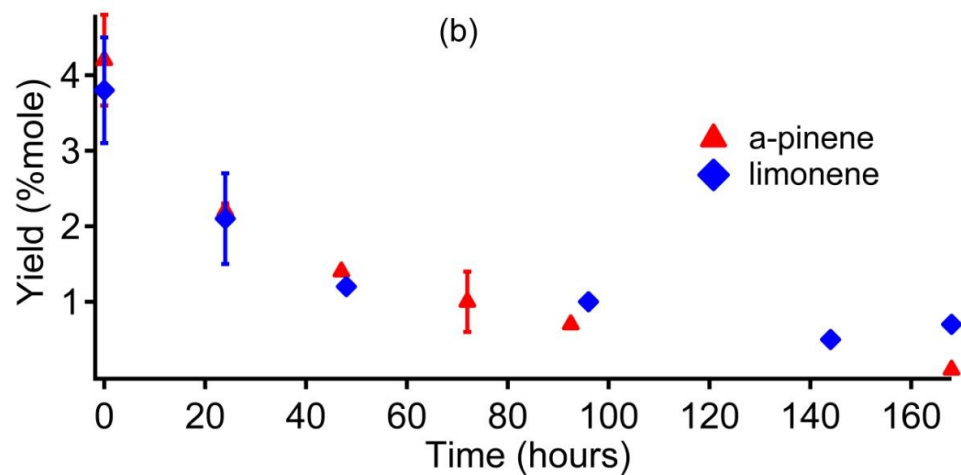

Figure S2. Stability of peroxides in SOA stored on-filter in the freezer at $-20\text{ }^{\circ}\text{C}$ (a) and at room temperature (b), and in solution at room temperature (c). Note that for the solution stability studies, the filters were 24 hours old before extraction occurred.